



**BELGARD**<sup>®</sup>  
**PAVES THE WAY**<sup>™</sup>

IDEA BOOK

**TANDEM**<sup>®</sup>  
**WALL SYSTEM**

REV: TD000EN

FACE UNITS

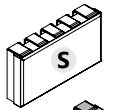

**SMALL  
FACE UNIT**  
7 x 13 1/4 x 2 3/8 in

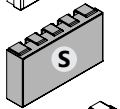

**SMALL  
FACE END UNIT**  
7 x 13 1/4 x 2 3/8 in

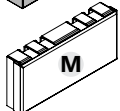

**MEDIUM  
FACE UNIT**  
7 x 15 1/4 x 2 3/8 in

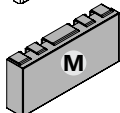

**MEDIUM  
FACE END UNIT**  
7 x 15 1/4 x 2 3/8 in

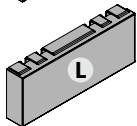

**LARGE  
FACE END UNIT**  
7 x 18 7/8 x 2 3/8 in

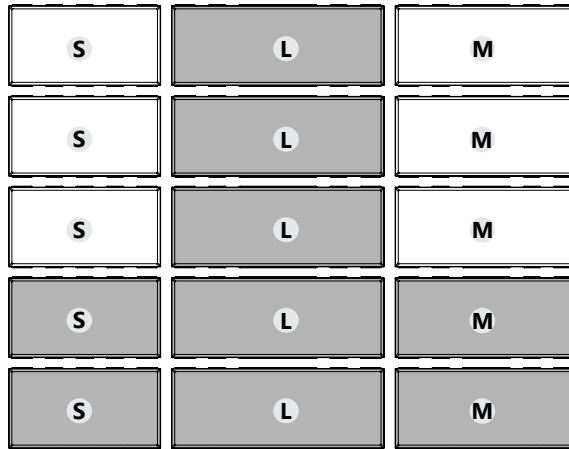

**TYPICAL ROW** SQUARE FEET/PALLET: 70.1 ft<sup>2</sup>  
 SQUARE FEET/LAYER: 11.63 ft<sup>2</sup>  
 LAYER/PALLET: 6  
 UNITS/PALLET: 90  
 UNITS/LAYER: 15  
 WEIGHT/PALLET: 1954 lb

U-START UNIT

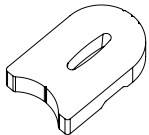

**U-START UNIT**  
18 7/8 x 16 x 3 3/8 in

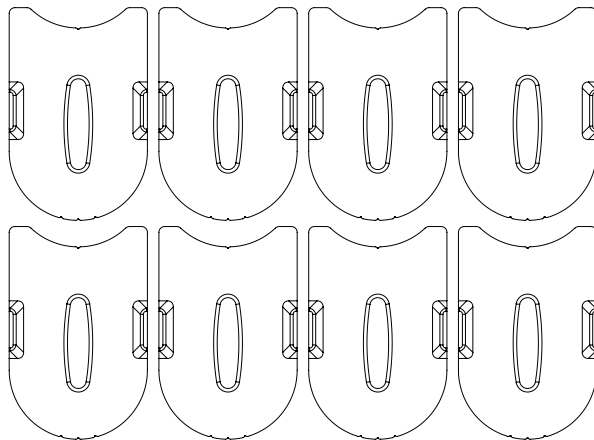

**TYPICAL ROW** LINEAR FEET/PALLET: 12.29 LF  
 LAYER/PALLET: 7  
 UNITS/PALLET: 56  
 UNITS/LAYER: 8  
 WEIGHT/PALLET: 3080 lb

MODULAR BLOCK

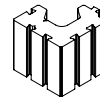

**MODULAR BLOCK**  
7 1/4 x 7 1/4 x 7 1/4 in  
20.58 lb

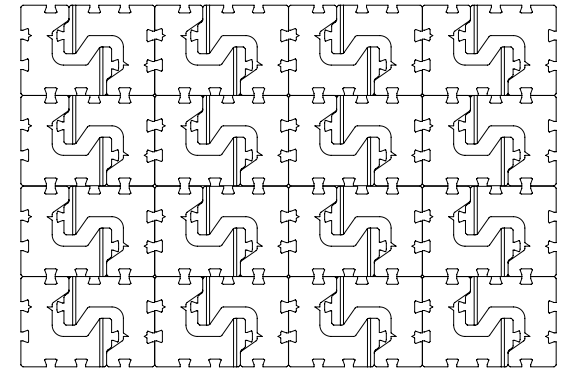

**UNIVERSAL CONNECTOR**  
5 3/4 x 1 1/4 x 7/8 in

ONE BOX: 148 UNITS  
 OR 4 BAGS OF 37 UNITS  
 \* ONE BOX INCLUDED WITH EVERY  
 MODULAR BLOCK PALLET

**TYPICAL ROW** SQUARE FEET/PALLET: 48.64 ft<sup>2</sup>  
 SQUARE FEET/LAYER: 12.16 ft<sup>2</sup>  
 LAYER/PALLET: 4  
 UNITS/PALLET: 128  
 UNITS/LAYER: 32  
 WEIGHT/PALLET: 2496 lb

SCAN TO LEARN  
 MORE ABOUT  
 TANDEM MODULAR BLOCK



# TABLE OF CONTENTS



# 1 | Planter Box

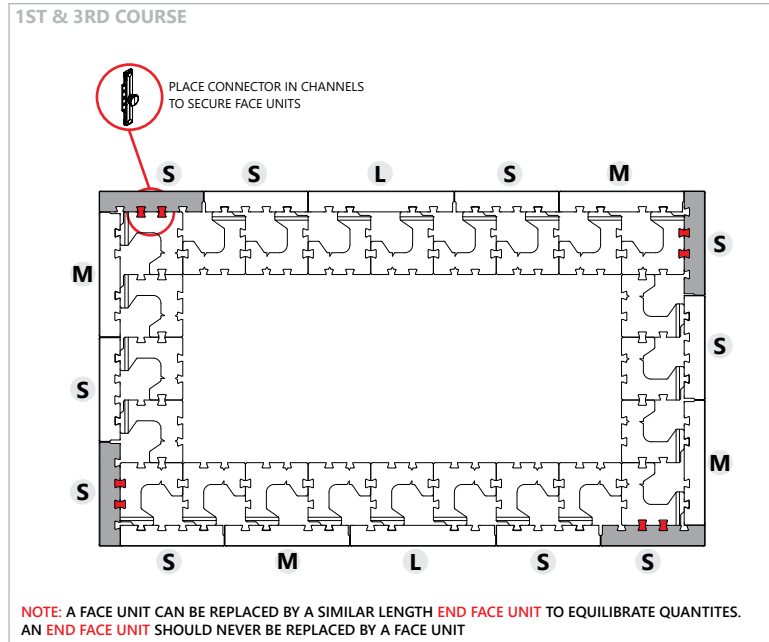
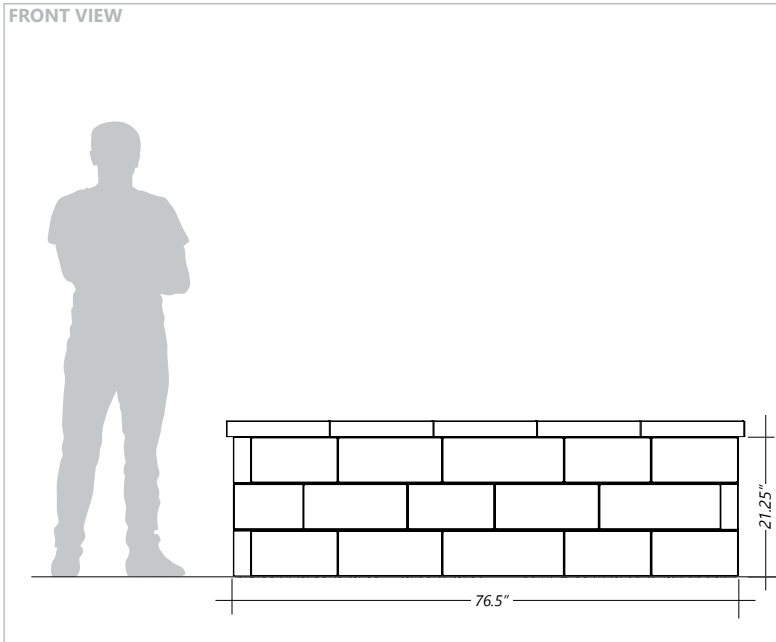
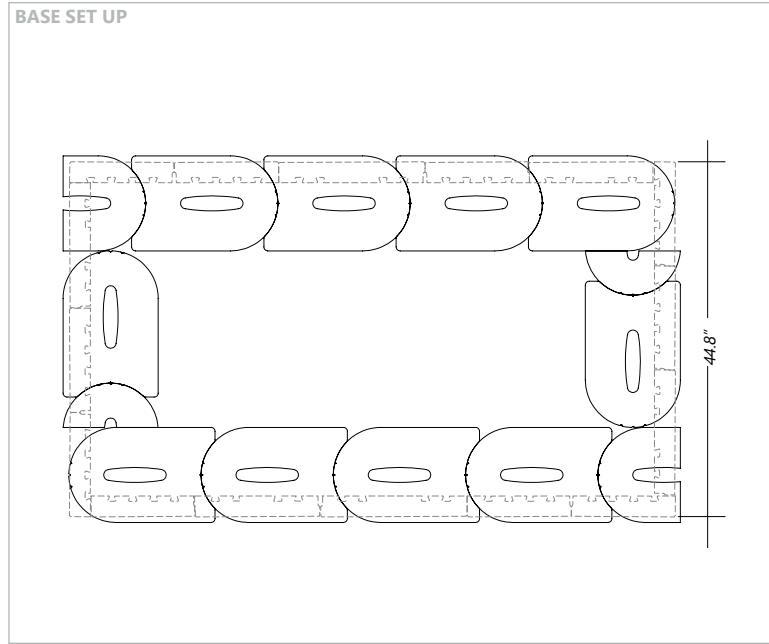

**COMPONENTS**  
NOTE: TANDEM UNITS ARE AVAILABLE IN MULTIPLE FACE STYLES

- SMALL FACE UNIT**  
7 x 13 13/16 x 2 5/8 in **16x**
- SMALL FACE END UNIT**  
7 x 13 13/16 x 2 5/8 in **12x**
- MEDIUM FACE UNIT**  
7 x 15 13/16 x 2 5/8 in **14x**
- MEDIUM FACE END UNIT**  
7 x 15 13/16 x 2 5/8 in **0x**
- LARGE FACE END UNIT**  
7 x 18 7/16 x 2 5/8 in **6x**

**TOTAL QTY OF PALLETS 1x**

- MODULAR BLOCK**  
7 1/16 x 7 7/8 x 7 7/8 in **72x**

**TOTAL QTY OF LAYERS 3x**

- UNIVERSAL CONNECTOR**  
5 3/4 x 1 1/4 x 7/8 in **24x**

- CAP**  
24 x 16 x 2 3/8 in **12x**

- U-START UNIT**  
18 7/16 x 16 x 3 3/8 in **14x**

**TOTAL WEIGHT 4131 Lbs**  
Estimated weight concrete only; variations may occur due to product changes and cuts

# 1 | Planter Box

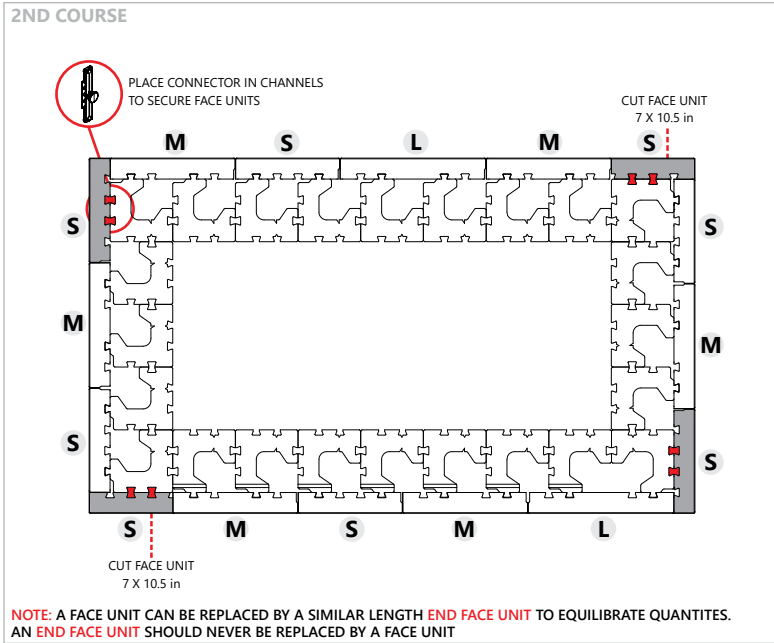

## COMPONENTS

NOTE: TANDEM UNITS ARE AVAILABLE IN MULTIPLE FACE STYLES

	<b>SMALL FACE UNIT</b> 7 x 13 13/16 x 2 5/8 in	<b>16x</b>
	<b>SMALL FACE END UNIT</b> 7 x 13 13/16 x 2 5/8 in	<b>12x</b>
	<b>MEDIUM FACE UNIT</b> 7 x 15 13/16 x 2 5/8 in	<b>14x</b>
	<b>MEDIUM FACE END UNIT</b> 7 x 15 13/16 x 2 5/8 in	<b>0x</b>
	<b>LARGE FACE END UNIT</b> 7 x 18 7/16 x 2 5/8 in	<b>6x</b>
<b>TOTAL QTY OF PALLETS</b>		<b>1x</b>
	<b>MODULAR BLOCK</b> 7 1/16 x 7 1/8 x 7 1/8 in	<b>72x</b>
<b>TOTAL QTY OF LAYERS</b>		<b>3x</b>
	<b>UNIVERSAL CONNECTOR</b> 5 3/4 x 1 1/4 x 1/8 in	<b>24x</b>
	<b>CAP</b> 24 x 16 x 2 3/8 in	<b>12x</b>
	<b>U-START UNIT</b> 18 1/16 x 16 x 3 5/8 in	<b>14x</b>
<b>TOTAL WEIGHT</b>		<b>4131 Lbs</b>
Estimated weight concrete only; variations may occur due to product changes and cuts		

# 2 | Small Bench

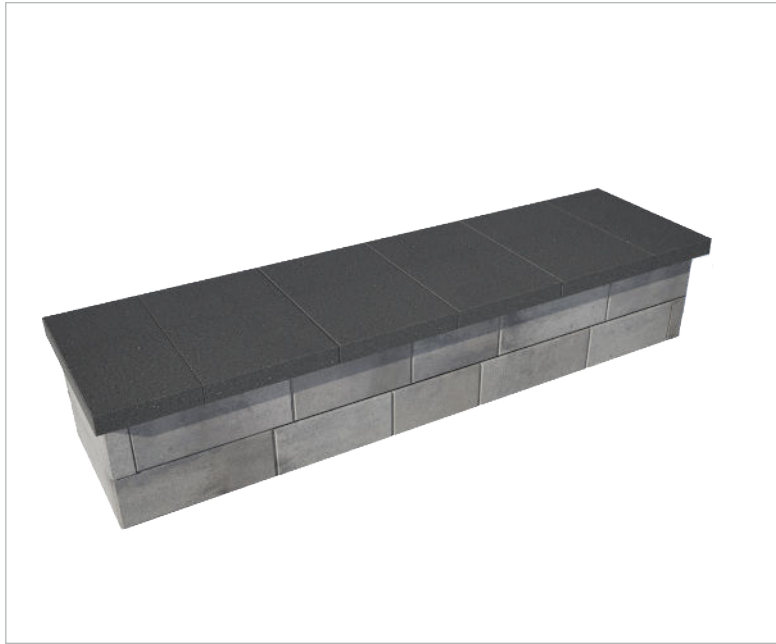

FRONT VIEW

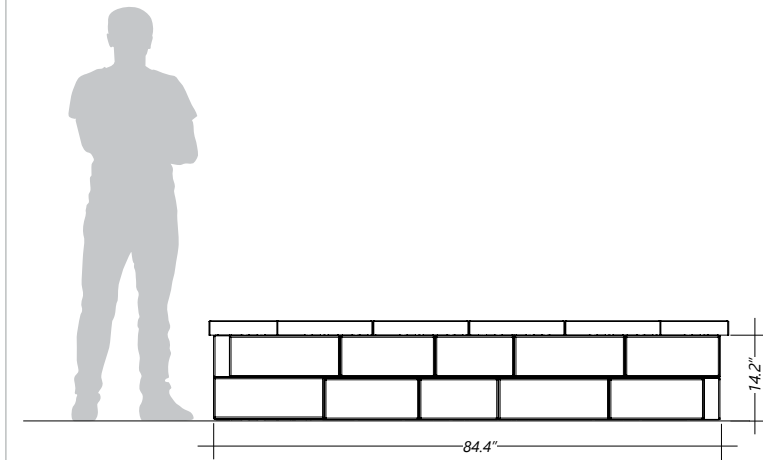

BASE SET UP

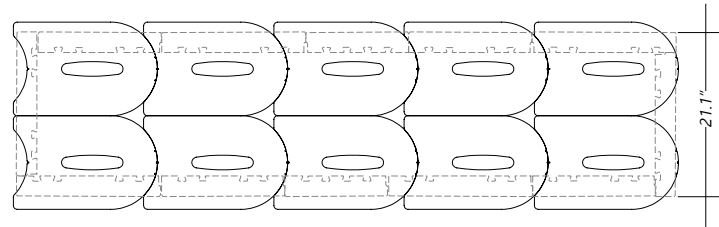

1ST COURSE

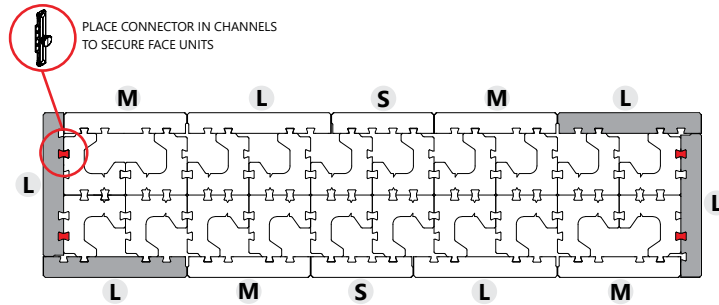

NOTE: A FACE UNIT CAN BE REPLACED BY A SIMILAR LENGTH END FACE UNIT TO EQUILIBRATE QUANTITIES. AN END FACE UNIT SHOULD NEVER BE REPLACED BY A FACE UNIT

2ND COURSE

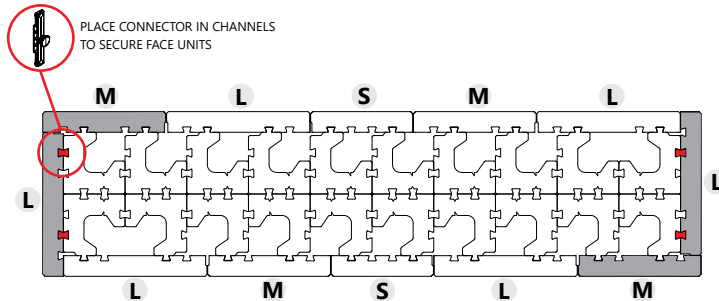

NOTE: A FACE UNIT CAN BE REPLACED BY A SIMILAR LENGTH END FACE UNIT TO EQUILIBRATE QUANTITIES. AN END FACE UNIT SHOULD NEVER BE REPLACED BY A FACE UNIT

COMPONENTS

NOTE: TANDEM UNITS ARE AVAILABLE IN MULTIPLE FACE STYLES

- SMALL FACE UNIT** 4x  
7 x 13 1/16 x 2 3/8 in
- SMALL FACE END UNIT** 0x  
7 x 13 1/16 x 2 3/8 in
- MEDIUM FACE UNIT** 6x  
7 x 15 1/16 x 2 3/8 in
- MEDIUM FACE END UNIT** 2x  
7 x 15 1/16 x 2 3/8 in
- LARGE FACE END UNIT** 12x  
7 x 18 7/16 x 2 3/8 in

TOTAL QTY OF PALLETS 1x

- MODULAR BLOCK** 40x  
7 1/16 x 7 7/8 x 7 7/8 in

TOTAL QTY OF LAYERS 2x

- UNIVERSAL CONNECTOR** 8x  
5 3/4 x 1 1/4 x 1/2 in

- CAP** 6x  
24 x 16 x 2 3/8 in

- U-START UNIT** 10x  
18 7/16 x 16 x 3 3/8 in

**TOTAL WEIGHT 2383 Lbs**  
Estimated weight concrete only; variations may occur due to product changes and cuts

# 3 | Seat Wall



BASE SET UP

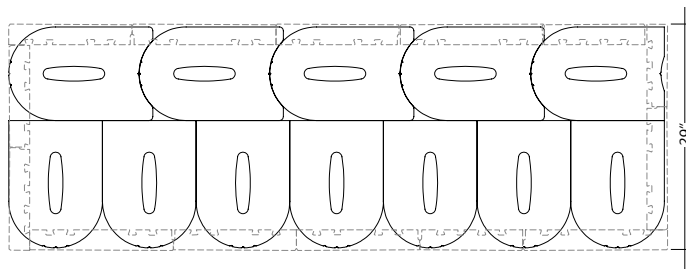

FRONT VIEW

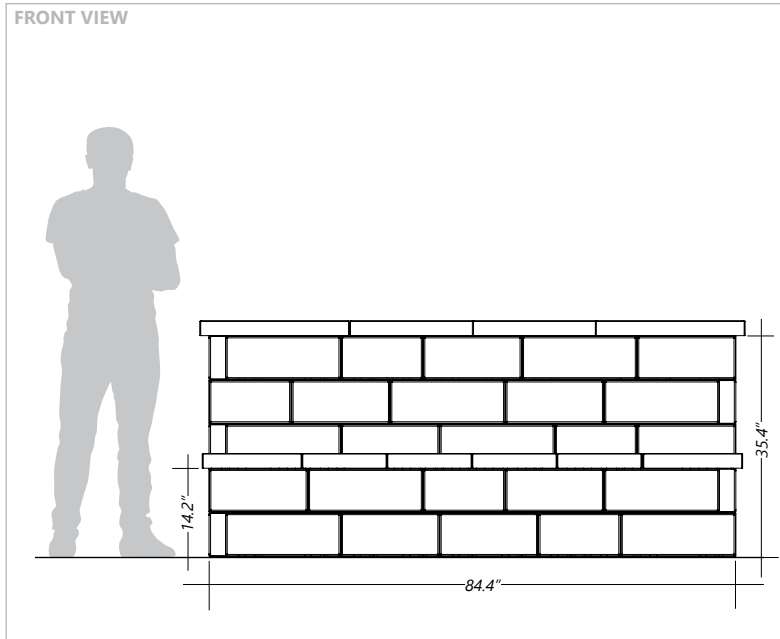

1ST COURSE

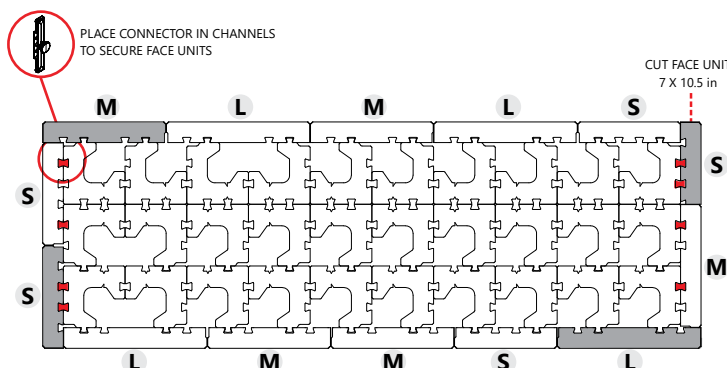

NOTE: A FACE UNIT CAN BE REPLACED BY A SIMILAR LENGTH END FACE UNIT TO EQUILIBRATE QUANTITIES. AN END FACE UNIT SHOULD NEVER BE REPLACED BY A FACE UNIT

**COMPONENTS**

NOTE: TANDEM UNITS ARE AVAILABLE IN MULTIPLE FACE STYLES

- SMALL FACE UNIT**  
7 x 13 13/16 x 2 5/8 in **12x**
- SMALL FACE END UNIT**  
7 x 13 13/16 x 2 5/8 in **11x**
- MEDIUM FACE UNIT**  
7 x 15 13/16 x 2 5/8 in **16x**
- MEDIUM FACE END UNIT**  
7 x 15 13/16 x 2 5/8 in **7x**
- LARGE FACE END UNIT**  
7 x 18 7/16 x 2 5/8 in **17x**

**TOTAL QTY OF PALLETS 1x**

- MODULAR BLOCK**  
7 1/16 x 7 7/8 x 7 7/8 in **90x**

**TOTAL QTY OF LAYERS 3x**

- UNIVERSAL CONNECTOR**  
5 3/4 x 1 1/4 x 7/8 in **58x**

- CAP**  
24 x 16 x 2 3/8 in **10x**

- U-START UNIT**  
18 7/16 x 16 x 3 5/8 in **12x**

**TOTAL WEIGHT 4656 Lbs**  
Estimated weight concrete only; variations may occur due to product changes and cuts

# 3 | Seat Wall

## 2ND COURSE

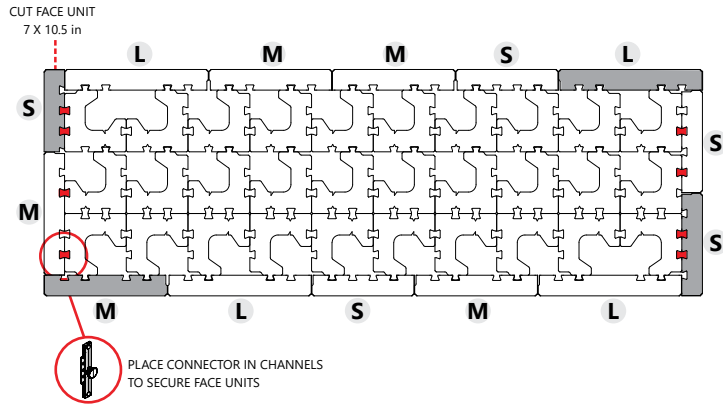

NOTE: A FACE UNIT CAN BE REPLACED BY A SIMILAR LENGTH END FACE UNIT TO EQUILIBRATE QUANTITIES. AN END FACE UNIT SHOULD NEVER BE REPLACED BY A FACE UNIT

## 4TH COURSE

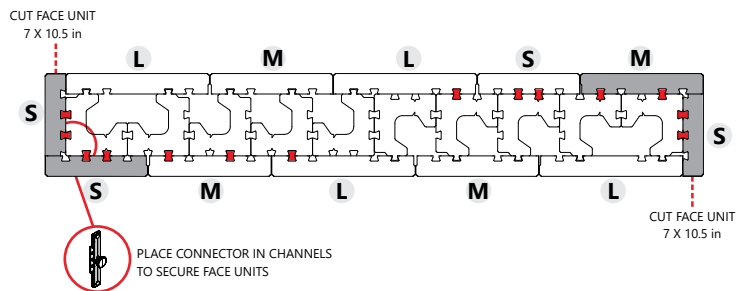

NOTE: A FACE UNIT CAN BE REPLACED BY A SIMILAR LENGTH END FACE UNIT TO EQUILIBRATE QUANTITIES. AN END FACE UNIT SHOULD NEVER BE REPLACED BY A FACE UNIT

## 3RD COURSE

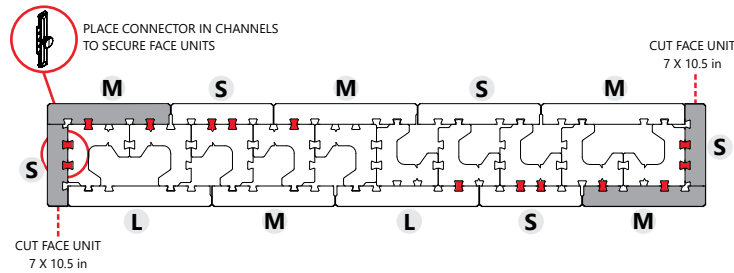

NOTE: A FACE UNIT CAN BE REPLACED BY A SIMILAR LENGTH END FACE UNIT TO EQUILIBRATE QUANTITIES. AN END FACE UNIT SHOULD NEVER BE REPLACED BY A FACE UNIT

## 5TH COURSE

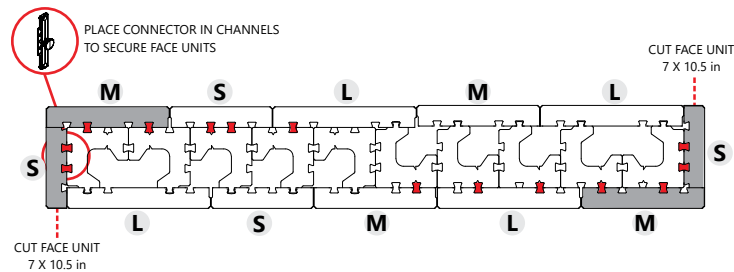

NOTE: A FACE UNIT CAN BE REPLACED BY A SIMILAR LENGTH END FACE UNIT TO EQUILIBRATE QUANTITIES. AN END FACE UNIT SHOULD NEVER BE REPLACED BY A FACE UNIT

## COMPONENTS

NOTE: TANDEM UNITS ARE AVAILABLE IN MULTIPLE FACE STYLES

- SMALL FACE UNIT**  
7 x 13 13/16 x 2 3/8 in **12x**
- SMALL FACE END UNIT**  
7 x 13 13/16 x 2 3/8 in **11x**
- MEDIUM FACE UNIT**  
7 x 15 13/16 x 2 3/8 in **16x**
- MEDIUM FACE END UNIT**  
7 x 15 13/16 x 2 3/8 in **7x**
- LARGE FACE END UNIT**  
7 x 18 7/16 x 2 3/8 in **17x**

**TOTAL QTY OF PALLETS 1x**

- MODULAR BLOCK**  
7 1/16 x 7 7/8 x 7 7/8 in **90x**

**TOTAL QTY OF LAYERS 3x**

- UNIVERSAL CONNECTOR**  
5 3/4 x 1 1/4 x 7/8 in **58x**

- CAP**  
24 x 16 x 2 3/8 in **10x**

- U-START UNIT**  
18 7/16 x 16 x 3 3/8 in **12x**

**TOTAL WEIGHT 4656 Lbs**

Estimated weight concrete only; variations may occur due to product changes and cuts

# 4 | Column & Freestanding Wall (FSW)



**NOTE :** This installation does not include a below-grade block course. If your wall design calls for one, add one more row of blocks at the bottom

FRONT VIEW

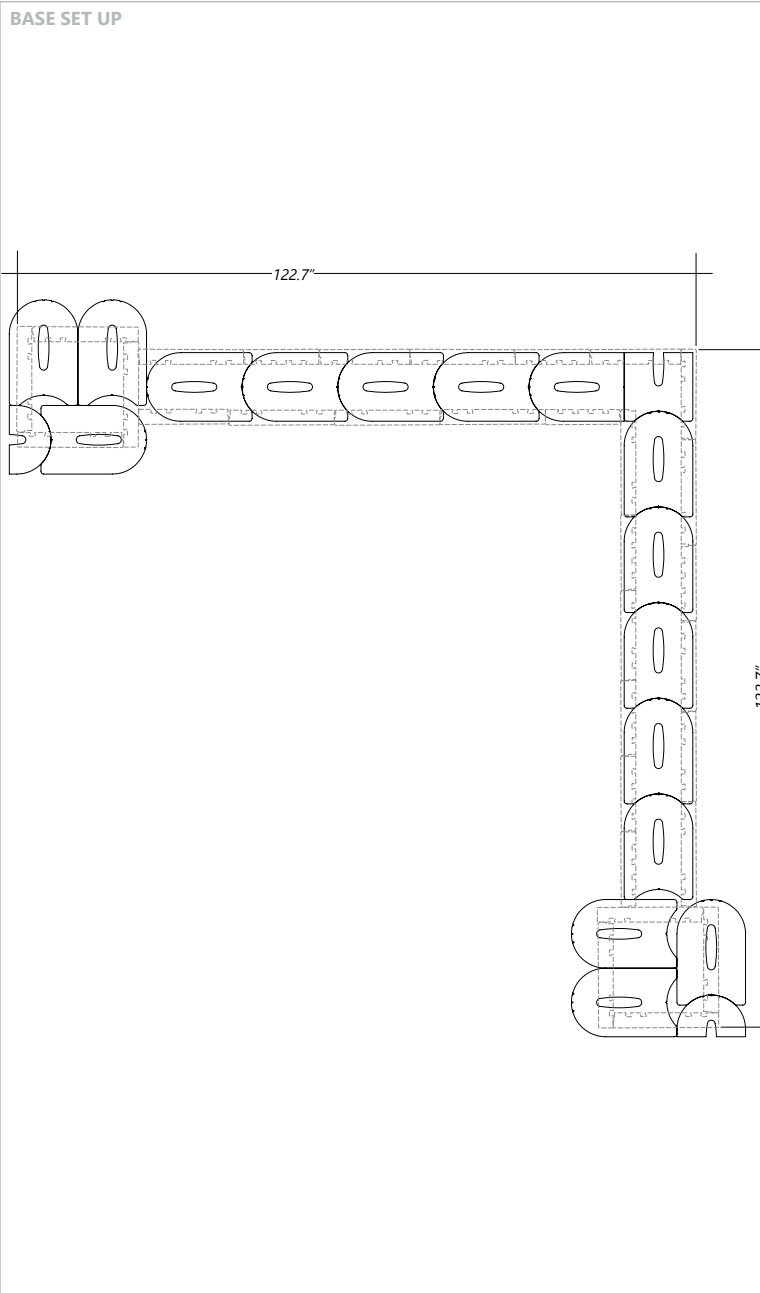
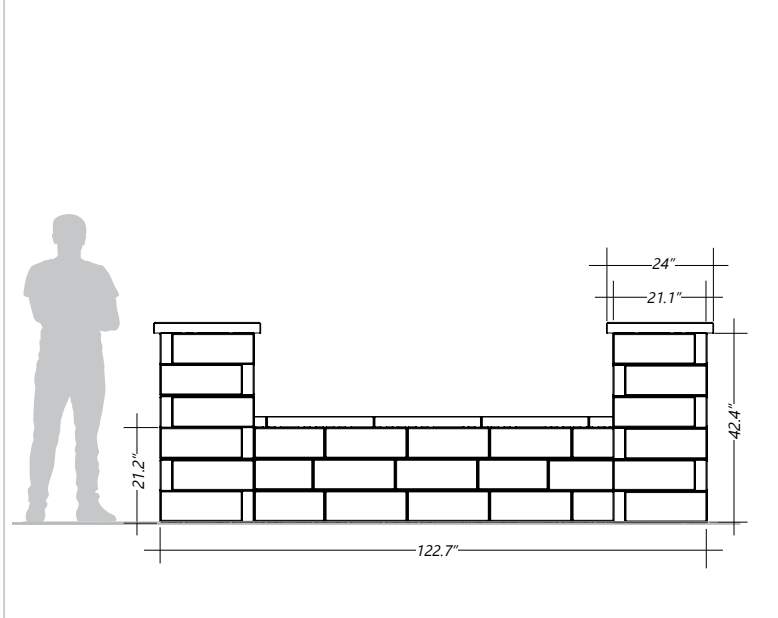

**COMPONENTS**  
NOTE: TANDEM UNITS ARE AVAILABLE IN MULTIPLE FACE STYLES

	<b>SMALL FACE UNIT</b> 7 x 13 13/16 x 2 5/8 in	<b>23x</b>
	<b>SMALL FACE END UNIT</b> 7 x 13 13/16 x 2 5/8 in	<b>0x</b>
	<b>MEDIUM FACE UNIT</b> 7 x 15 13/16 x 2 5/8 in	<b>20x</b>
	<b>MEDIUM FACE END UNIT</b> 7 x 15 13/16 x 2 5/8 in	<b>3x</b>
	<b>LARGE FACE END UNIT</b> 7 x 18 7/16 x 2 5/8 in	<b>71x</b>
<b>TOTAL QTY OF PALLETS</b>		<b>3x</b>
<small>*Use the Tandem column kit where available.</small>		
	<b>MODULAR BLOCK</b> 7 1/16 x 7 7/8 x 7 7/8 in	<b>117x</b>
<b>TOTAL QTY OF LAYERS</b>		<b>4x</b>
	<b>UNIVERSAL CONNECTOR</b> 5 3/4 x 1 1/4 x 7/8 in	<b>165x</b>
	<b>CAP</b> 24 x 16 x 2 3/8 in	<b>9x</b>
	<b>CAP</b> 24 x 24 x 2 3/8 in	<b>2x</b>
	<b>U-START UNIT</b> 18 7/16 x 16 x 3 5/8 in	<b>19x</b>

**TOTAL WEIGHT 7111 Lbs**  
Estimated weight concrete only, variations may occur due to product changes and cuts

# 4 | Column & Freestanding Wall (FSW)

1ST & 3RD COURSE FSW  
1ST, 3RD & 5TH COURSE COLUMN

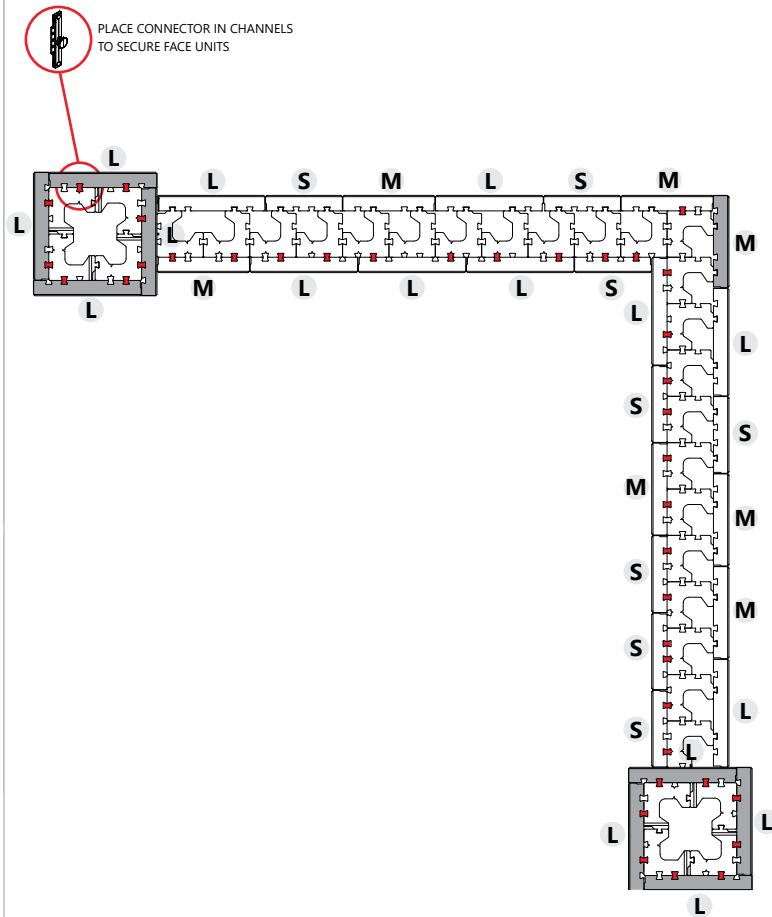

NOTE: A FACE UNIT CAN BE REPLACED BY A SIMILAR LENGTH END FACE UNIT TO EQUILIBRATE QUANTITIES. AN END FACE UNIT SHOULD NEVER BE REPLACED BY A FACE UNIT

2ND COURSE FSW  
2ND, 4TH & 6TH COURSE COLUMN

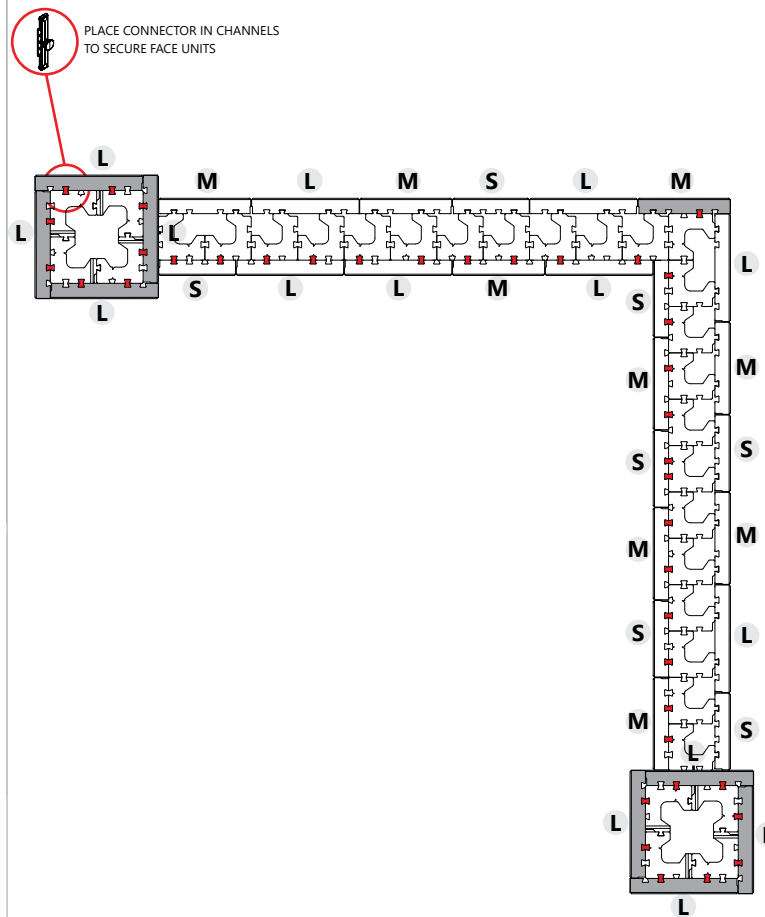

NOTE: A FACE UNIT CAN BE REPLACED BY A SIMILAR LENGTH END FACE UNIT TO EQUILIBRATE QUANTITIES. AN END FACE UNIT SHOULD NEVER BE REPLACED BY A FACE UNIT

## COMPONENTS

NOTE: TANDEM UNITS ARE AVAILABLE IN MULTIPLE FACE STYLES

- SMALL FACE UNIT** 7 x 13 13/16 x 2 5/8 in **23x**
- SMALL FACE END UNIT** 7 x 13 13/16 x 2 5/8 in **0x**
- MEDIUM FACE UNIT** 7 x 15 13/16 x 2 5/8 in **20x**
- MEDIUM FACE END UNIT** 7 x 15 13/16 x 2 5/8 in **3x**
- LARGE FACE END UNIT** 7 x 18 7/16 x 2 5/8 in **71x**
- TOTAL QTY OF PALLETS** **3x**  
\*Use the Tandem column kit where available.
- MODULAR BLOCK** 7 1/16 x 7 7/8 x 7 7/8 in **117x**
- TOTAL QTY OF LAYERS** **4x**
- UNIVERSAL CONNECTOR** 5 3/4 x 1 1/4 x 7/8 in **165x**
- CAP** 24 x 16 x 2 5/8 in **9x**
- U-START UNIT** 18 7/16 x 16 x 3 5/8 in **19x**

**TOTAL WEIGHT 7111 Lbs**

Estimated weight concrete only; variations may occur due to product changes and cuts

# 5 | Column Around Post

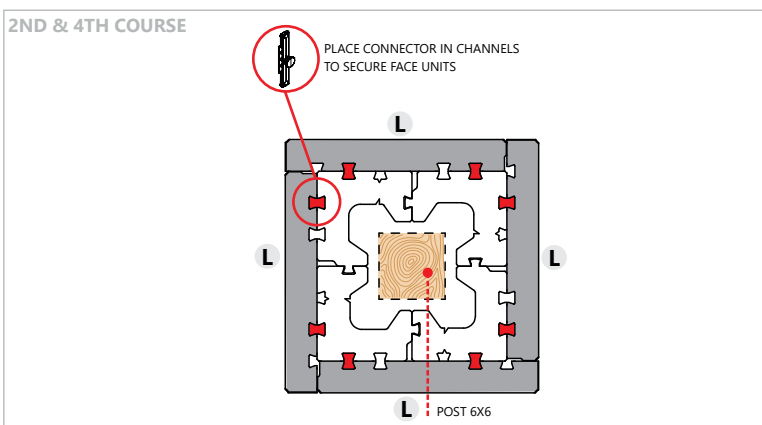
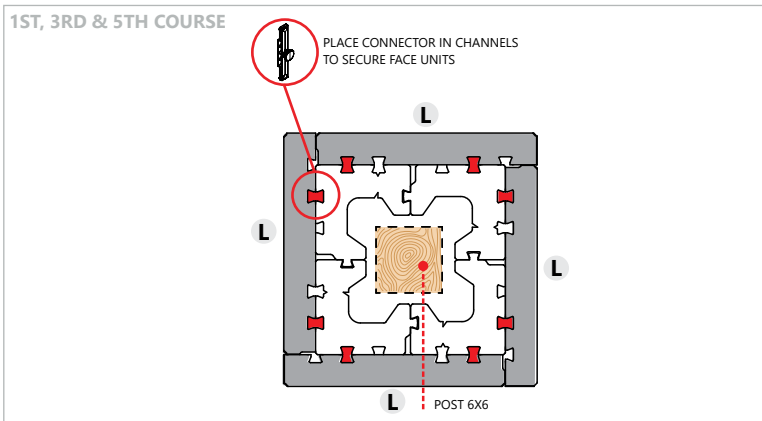
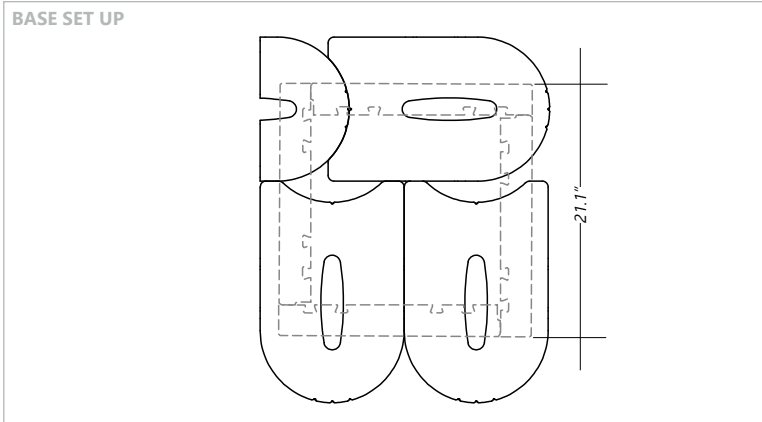
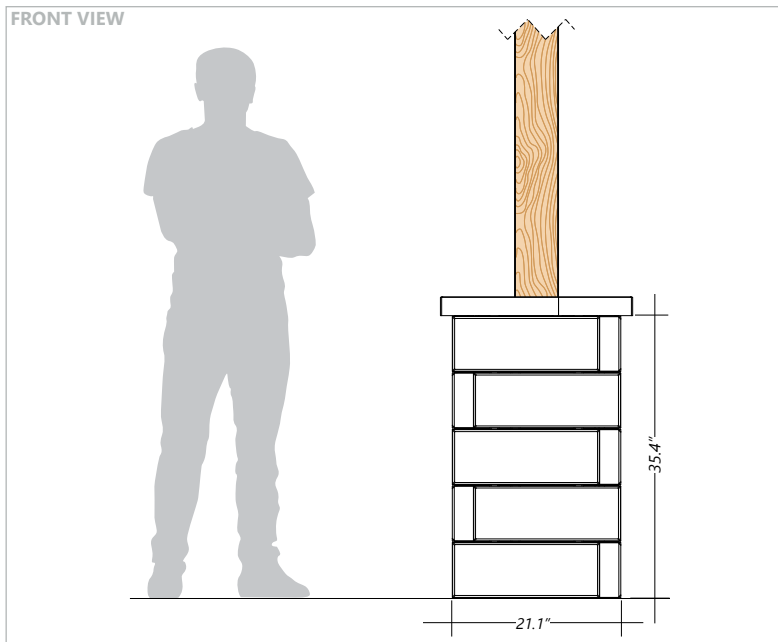
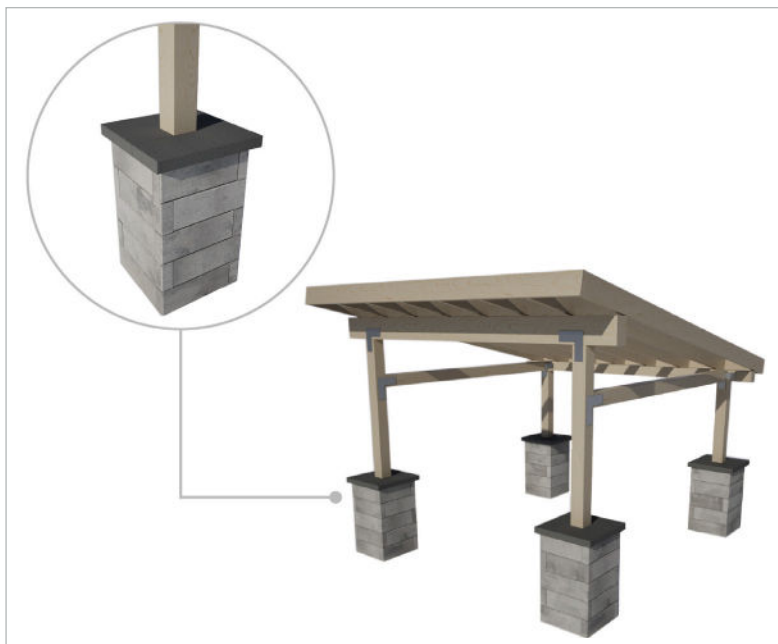

**COMPONENTS**  
NOTE: TANDEM UNITS ARE AVAILABLE IN MULTIPLE FACE STYLES

	<b>SMALL FACE UNIT</b> 7 x 13 1/8 x 2 3/8 in	<b>0x</b>
	<b>SMALL FACE END UNIT</b> 7 x 13 1/8 x 2 3/8 in	<b>0x</b>
	<b>MEDIUM FACE UNIT</b> 7 x 15 1/8 x 2 3/8 in	<b>0x</b>
	<b>MEDIUM FACE END UNIT</b> 7 x 15 1/8 x 2 3/8 in	<b>0x</b>
	<b>LARGE FACE END UNIT</b> 7 x 18 1/8 x 2 3/8 in	<b>20x</b>
<b>TOTAL QTY OF PALLETS</b> *Use the Tandem column kit where available.		<b>1x</b>
	<b>MODULAR BLOCK</b> 7 1/8 x 7 1/8 x 7 1/8 in	<b>20x</b>
<b>TOTAL QTY OF LAYERS</b>		<b>1x</b>
	<b>UNIVERSAL CONNECTOR</b> 5 3/4 x 1 1/4 x 1/8 in	<b>40x</b>
	<b>CAP</b> 24 x 16 x 2 3/8 in	<b>4x</b>
	<b>U-START UNIT</b> 18 1/8 x 16 x 3 3/8 in	<b>4x</b>

**TOTAL WEIGHT 1463 Lbs**  
Estimated weight concrete only, variations may occur due to product changes and cuts

# 6 | Square Gas Fire Pit



FRONT VIEW

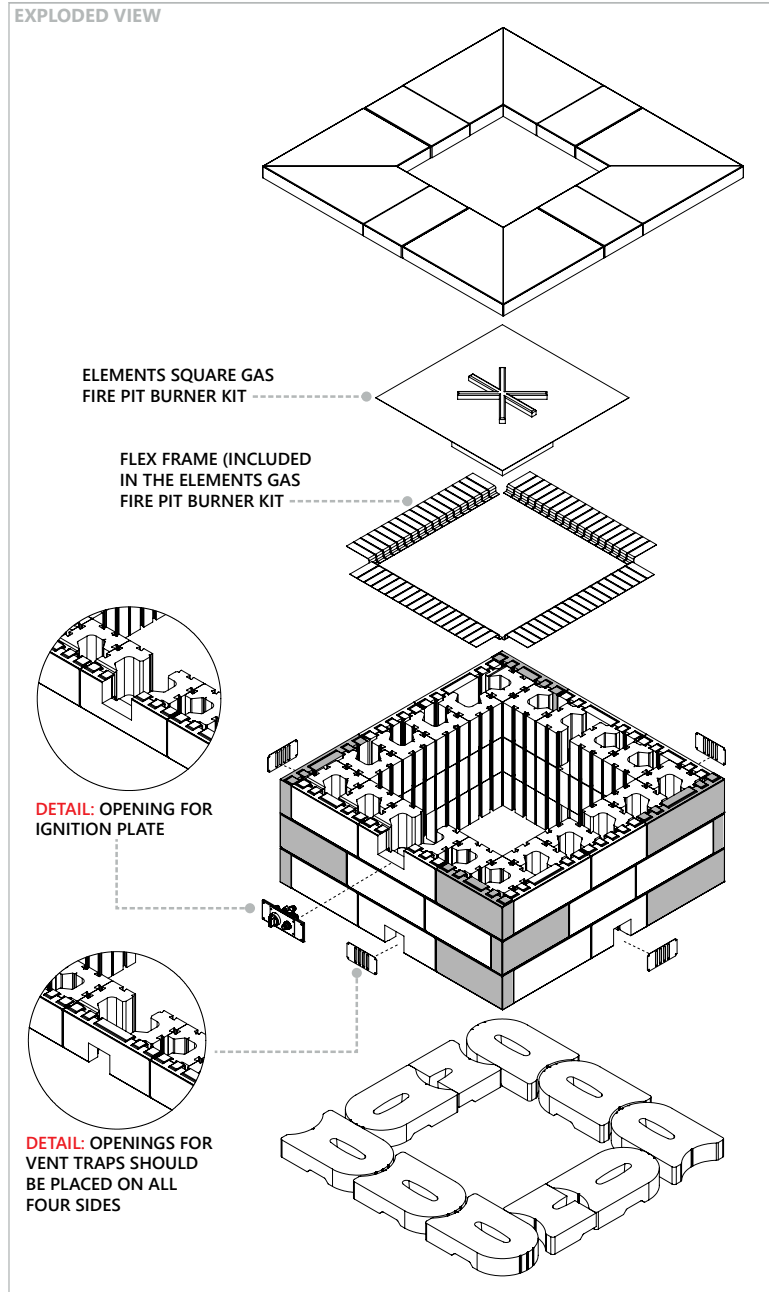
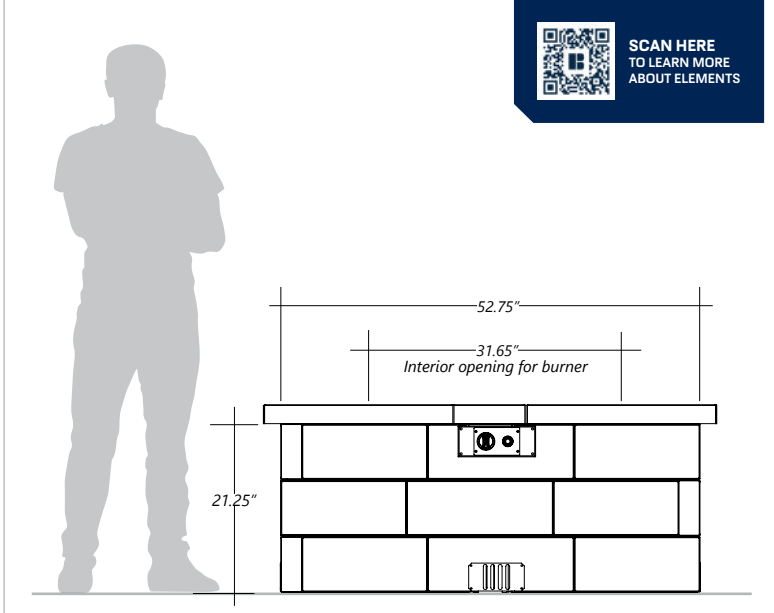

**COMPONENTS**  
NOTE: TANDEM UNITS ARE AVAILABLE IN MULTIPLE FACE STYLES

	<b>SMALL FACE UNIT</b> 7 x 13 1/16 x 2 5/8 in	<b>4x</b>
	<b>SMALL FACE END UNIT</b> 7 x 13 1/16 x 2 5/8 in	<b>0x</b>
	<b>MEDIUM FACE UNIT</b> 7 x 15 1/16 x 2 5/8 in	<b>8x</b>
	<b>MEDIUM FACE END UNIT</b> 7 x 15 1/16 x 2 5/8 in	<b>8x</b>
	<b>LARGE FACE END UNIT</b> 7 x 18 7/16 x 2 5/8 in	<b>16x</b>
<b>TOTAL QTY OF PALLETS</b>		<b>1x</b>
	<b>MODULAR BLOCK</b> 7 1/16 x 7 7/8 x 7 7/8 in	<b>60x</b>
<b>TOTAL QTY OF LAYERS</b>		<b>2x</b>
	<b>UNIVERSAL CONNECTOR</b> 5 3/4 x 1 1/4 x 7/8 in	<b>12x</b>
	<b>CAP</b> 24 x 16 x 2 5/8 in	<b>12x</b>
	<b>U-START UNIT</b> 18 7/16 x 16 x 3 5/8 in	<b>10x</b>

**IMPORTANT:** It is recommended to follow the burner manufacturer's specifications for ventilation. Belgard is not responsible for the conformity of connections, clearances and ventilation. Burner pan and accessories are not included. PROPOSED MODEL: *Linzel SQUARE Burner 30" PLATE KIT*

# 6 | Square Gas Fire Pit

## BASE SET UP

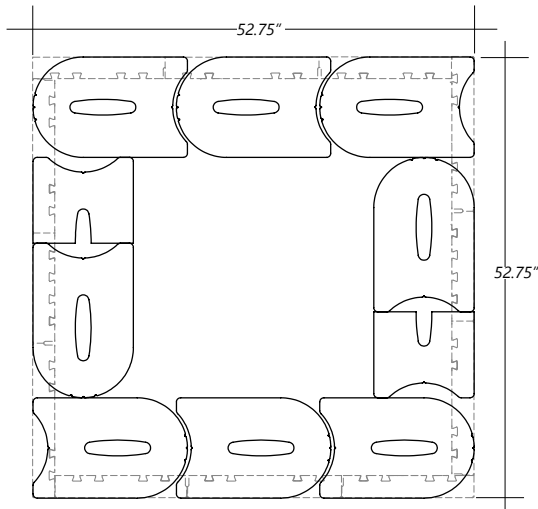

## 1ST COURSE

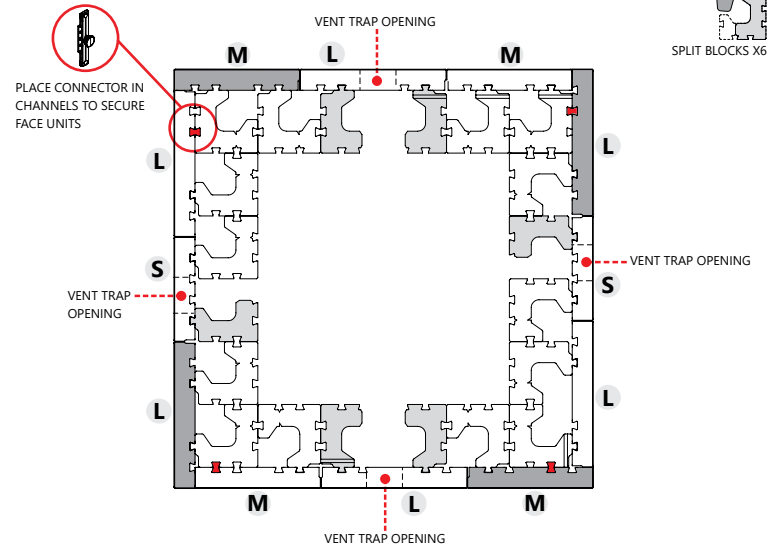

**NOTE:** A FACE UNIT CAN BE REPLACED BY A SIMILAR LENGTH **END FACE UNIT** TO EQUILIBRATE QUANTITIES. AN **END FACE UNIT** SHOULD NEVER BE REPLACED BY A FACE UNIT

## 2ND COURSE

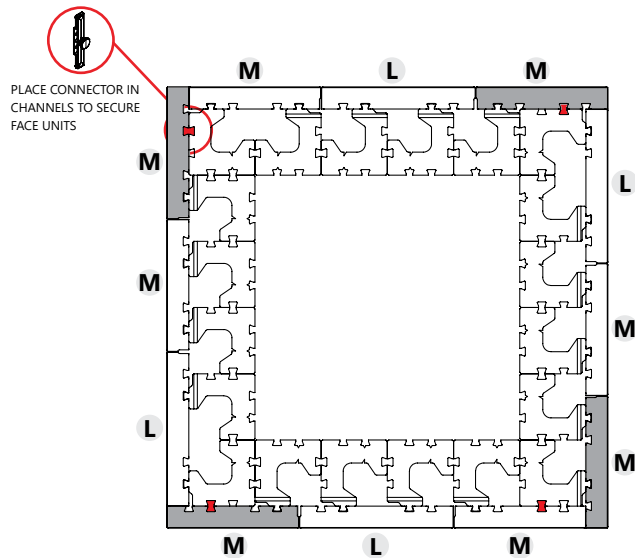

**NOTE:** A FACE UNIT CAN BE REPLACED BY A SIMILAR LENGTH **END FACE UNIT** TO EQUILIBRATE QUANTITIES. AN **END FACE UNIT** SHOULD NEVER BE REPLACED BY A FACE UNIT

## 3RD COURSE

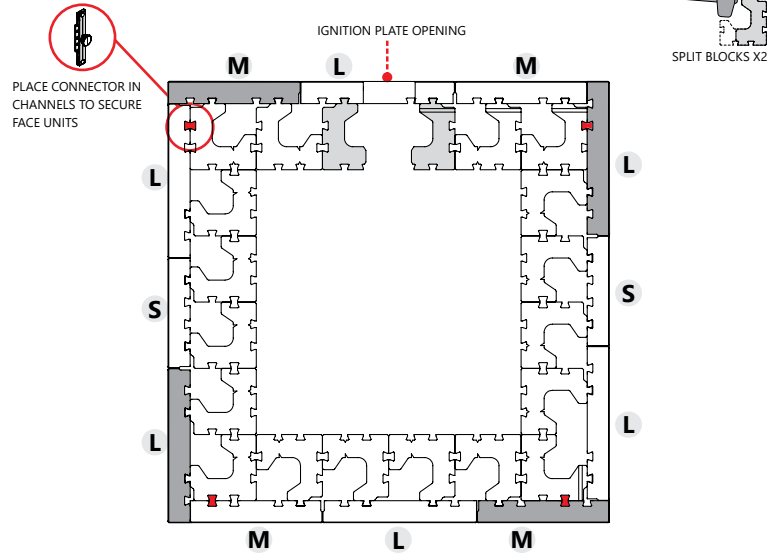

**NOTE:** A FACE UNIT CAN BE REPLACED BY A SIMILAR LENGTH **END FACE UNIT** TO EQUILIBRATE QUANTITIES. AN **END FACE UNIT** SHOULD NEVER BE REPLACED BY A FACE UNIT

## COMPONENTS

**NOTE:** TANDEM UNITS ARE AVAILABLE IN MULTIPLE FACE STYLES

- SMALL FACE UNIT**  
7 x 13 13/16 x 2 5/8 in **4x**
- SMALL FACE END UNIT**  
7 x 13 13/16 x 2 5/8 in **0x**
- MEDIUM FACE UNIT**  
7 x 15 13/16 x 2 5/8 in **8x**
- MEDIUM FACE END UNIT**  
7 x 15 13/16 x 2 5/8 in **8x**
- LARGE FACE END UNIT**  
7 x 18 7/16 x 2 5/8 in **16x**

**TOTAL QTY OF PALLETS** **1x**

- MODULAR BLOCK**  
7 1/16 x 7 7/8 x 7 7/8 in **60x**

**TOTAL QTY OF LAYERS** **2x**

- UNIVERSAL CONNECTOR**  
5 3/4 x 1 1/4 x 7/8 in **12x**

- CAP**  
24 x 16 x 2 3/8 in **12x**

- U-START UNIT**  
18 7/16 x 16 x 3 5/8 in **10x**

**TOTAL WEIGHT 3537 Lbs**  
Estimated weight concrete only; variations may occur due to product changes and cuts

**IMPORTANT:** It is recommended to follow the burner manufacturer's specifications for ventilation. Belgard is not responsible for the conformity of connections, clearances and ventilation. Burner pan and accessories are not included. PROPOSED MODEL: Linzel SQUARE Burner 30" PLATE KIT

# 7 | Rectangular Gas Fire Pit



FRONT VIEW

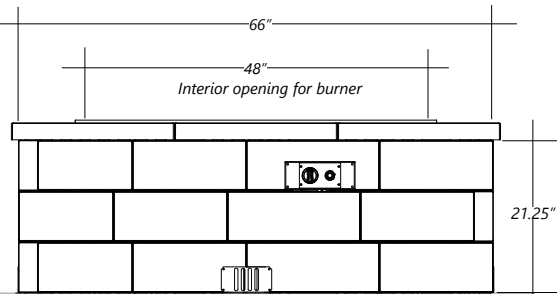
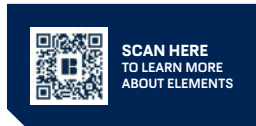

**IMPORTANT:** It is recommended to follow the burner manufacturer's specifications for ventilation. Belgard is not responsible for the conformity of connections, clearances and ventilation. Burner pan and accessories are not included. PROPOSED MODEL: Linzel H-STYLE Burner 46" x 17" PLATE KIT

EXPLODED VIEW

ELEMENTS 18 x 48"  
LINEAR FIRE PIT BURNER PAN

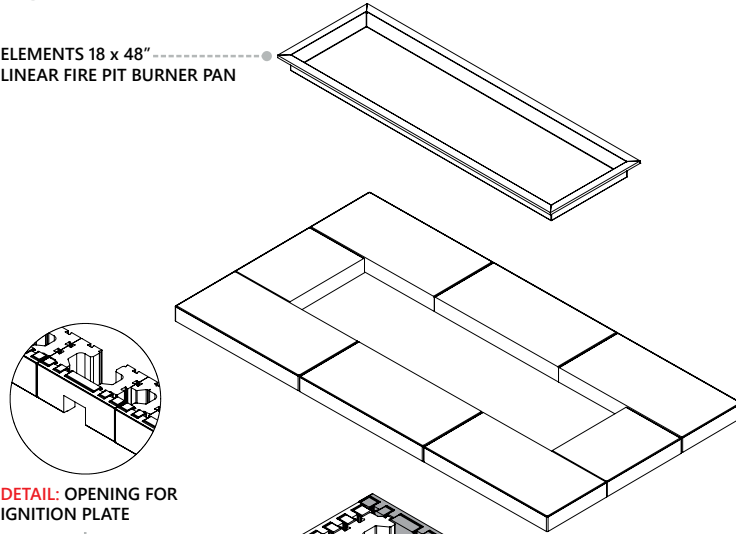

DETAIL: OPENING FOR IGNITION PLATE

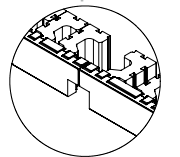
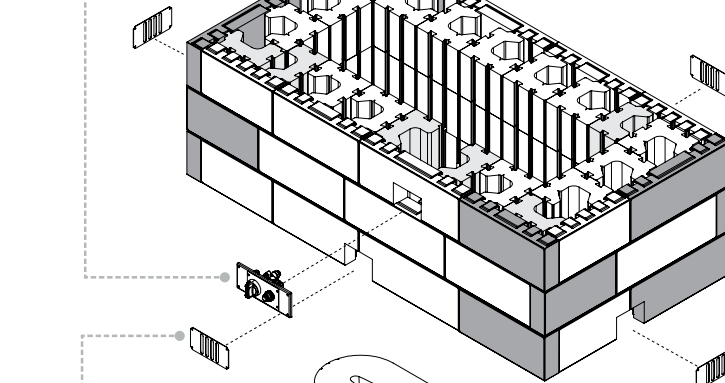

DETAIL: OPENINGS FOR VENT TRAPS SHOULD BE PLACED ON ALL FOUR SIDES

**COMPONENTS**

NOTE: TANDEM UNITS ARE AVAILABLE IN MULTIPLE FACE STYLES

- SMALL FACE UNIT** 8x  
7 x 13 1/16 x 2 3/8 in
- SMALL FACE END UNIT** 4x  
7 x 13 1/16 x 2 3/8 in
- MEDIUM FACE UNIT** 8x  
7 x 15 1/16 x 2 3/8 in
- MEDIUM FACE END UNIT** 4x  
7 x 15 1/16 x 2 3/8 in
- LARGE FACE END UNIT** 11x  
7 x 18 7/16 x 2 3/8 in
- TOTAL QTY OF PALLETS** 1x
- MODULAR BLOCK** 58x  
7 1/16 x 7 7/8 x 7 7/8 in
- TOTAL QTY OF LAYERS** 2x
- UNIVERSAL CONNECTOR** 14x  
5 3/4 x 1 1/4 x 1/8 in
- CAP** 8x  
24 x 16 x 2 3/8 in
- U-START UNIT** 10x  
18 7/16 x 16 x 3 3/8 in

**TOTAL WEIGHT 3146 Lbs**  
Estimated weight concrete only; variations may occur due to product changes and cuts

# 7 | Rectangular Gas Fire Pit

BASE SET UP

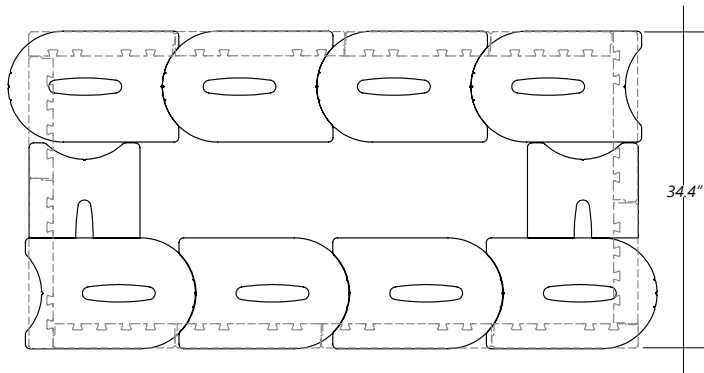

1ST COURSE

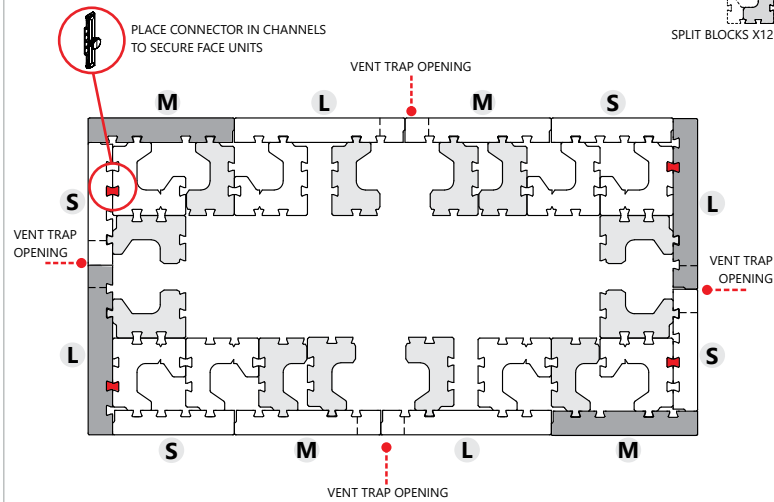

**NOTE:** A FACE UNIT CAN BE REPLACED BY A SIMILAR LENGTH **END FACE UNIT** TO EQUILIBRATE QUANTITIES. AN **END FACE UNIT** SHOULD NEVER BE REPLACED BY A FACE UNIT

2ND COURSE

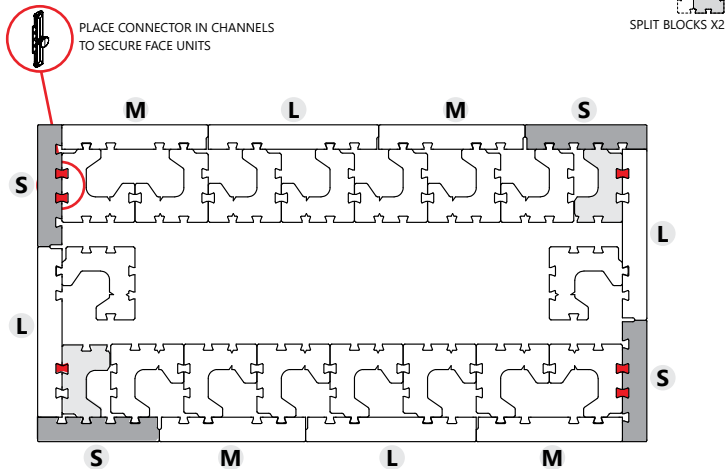

**NOTE:** A FACE UNIT CAN BE REPLACED BY A SIMILAR LENGTH **END FACE UNIT** TO EQUILIBRATE QUANTITIES. AN **END FACE UNIT** SHOULD NEVER BE REPLACED BY A FACE UNIT

3RD COURSE

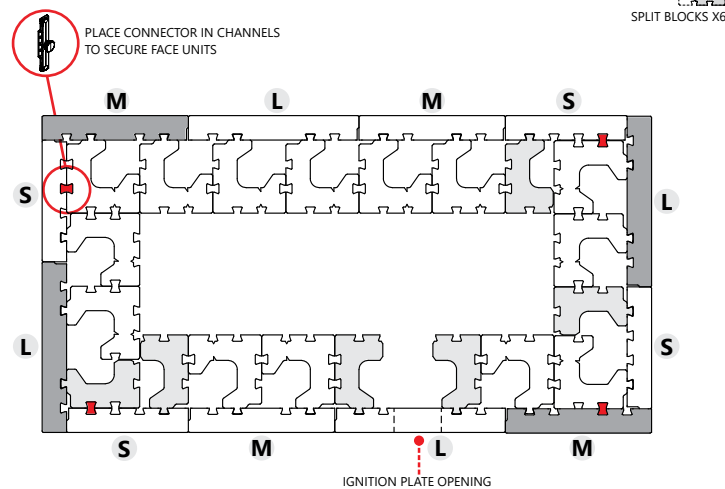

**NOTE:** A FACE UNIT CAN BE REPLACED BY A SIMILAR LENGTH **END FACE UNIT** TO EQUILIBRATE QUANTITIES. AN **END FACE UNIT** SHOULD NEVER BE REPLACED BY A FACE UNIT

**COMPONENTS**

**NOTE:** TANDEM UNITS ARE AVAILABLE IN MULTIPLE FACE STYLES

- SMALL FACE UNIT**  
7 x 13 1/16 x 2 3/8 in **8x**
- SMALL FACE END UNIT**  
7 x 13 1/16 x 2 3/8 in **4x**
- MEDIUM FACE UNIT**  
7 x 15 1/16 x 2 3/8 in **8x**
- MEDIUM FACE END UNIT**  
7 x 15 1/16 x 2 3/8 in **4x**
- LARGE FACE END UNIT**  
7 x 18 7/16 x 2 3/8 in **11x**

**TOTAL QTY OF PALLETS** **1x**

- MODULAR BLOCK**  
7 1/16 x 7 7/16 x 7 7/16 in **58x**

**TOTAL QTY OF LAYERS** **2x**

- UNIVERSAL CONNECTOR**  
5 3/4 x 1 1/4 x 7/16 in **14x**

- CAP**  
24 x 16 x 2 3/8 in **8x**

- U-START UNIT**  
18 7/16 x 16 x 3 3/8 in **10x**

**TOTAL WEIGHT 3146 Lbs**  
Estimated weight concrete only; variations may occur due to product changes and cuts

**IMPORTANT:** It is recommended to follow the burner manufacturer's specifications for ventilation. Belgard is not responsible for the conformity of connections, clearances and ventilation. Burner pan and accessories are not included. PROPOSED MODEL: Linzel H-STYLE Burner 46" x 17" PLATE KIT

# 8 | Grill Island



FRONT VIEW

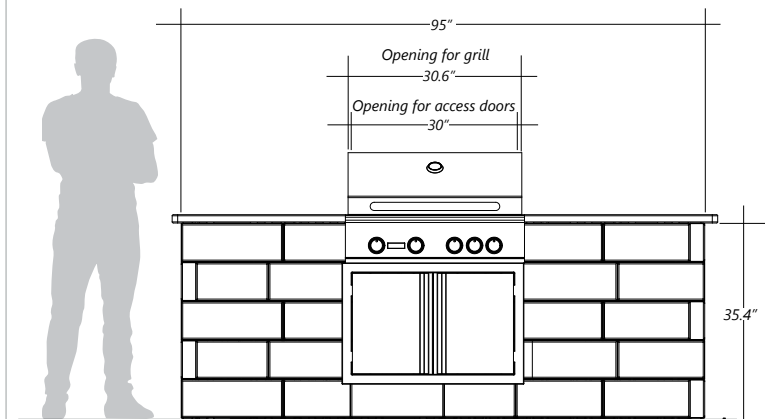
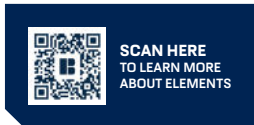

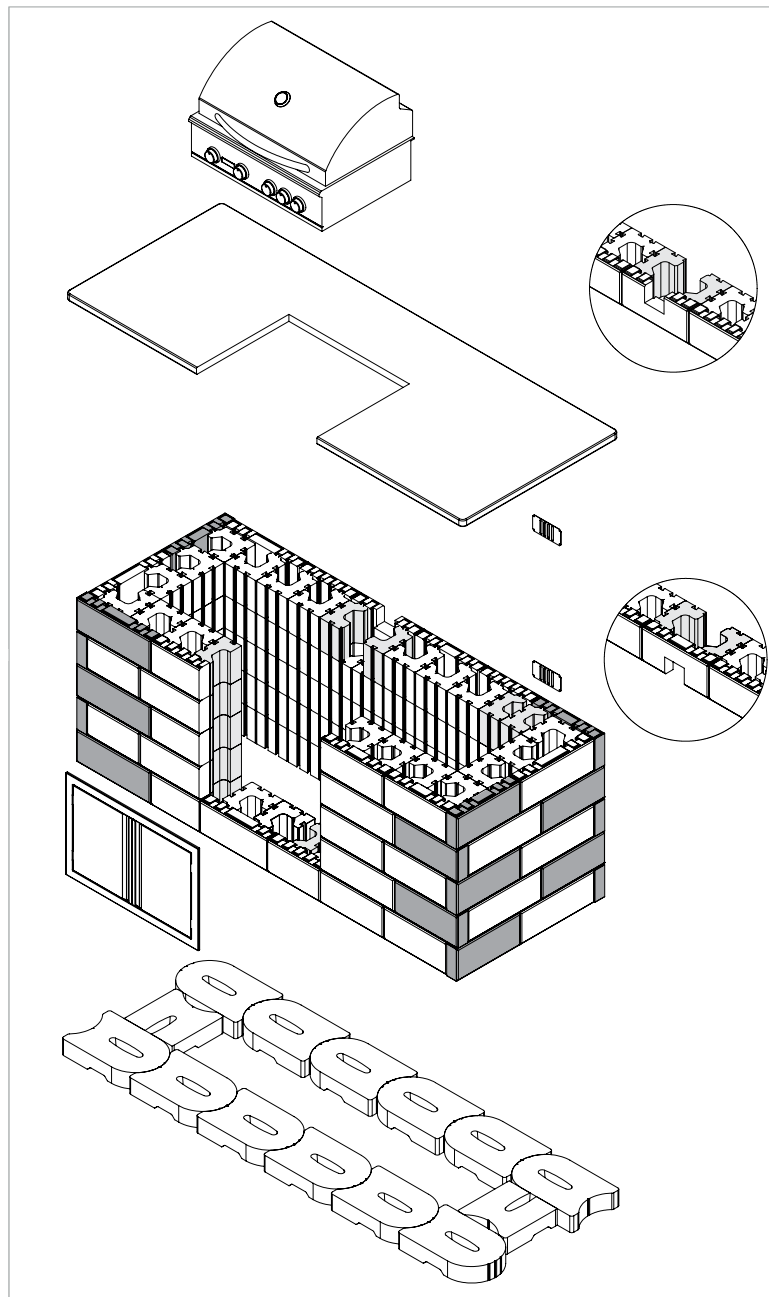

**IMPORTANT:** It is recommended to follow the BBQ manufacturer's specifications for ventilation and clearances. Belgard is not responsible for the conformity, clearances and ventilation. BBQ, countertop and accessories are not included

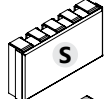
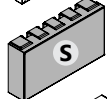
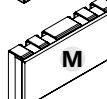
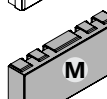
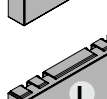
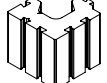

### COMPONENTS

NOTE: TANDEM UNITS ARE AVAILABLE IN MULTIPLE FACE STYLES

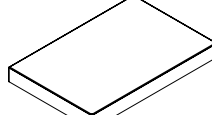
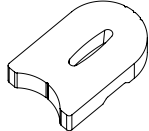
-  **SMALL FACE UNIT** 7 x 13 13/16 x 2 5/8 in **16x**
-  **SMALL FACE END UNIT** 7 x 13 13/16 x 2 5/8 in **0x**
-  **MEDIUM FACE UNIT** 7 x 15 13/16 x 2 5/8 in **15x**
-  **MEDIUM FACE END UNIT** 7 x 15 13/16 x 2 5/8 in **14x**
-  **LARGE FACE END UNIT** 7 x 18 7/16 x 2 5/8 in **25x**
- TOTAL QTY OF PALLETS** **1x**
-  **MODULAR BLOCK** 7 1/16 x 7 7/8 x 7 7/8 in **124x**
- TOTAL QTY OF LAYERS** **4x**
-  **UNIVERSAL CONNECTOR** 5 3/4 x 1 1/4 x 7/8 in **20x**
-  **CAP** 24 x 16 x 2 3/8 in **0x**
-  **U-START UNIT** 18 7/16 x 16 x 3 5/8 in **14x**

**TOTAL WEIGHT 4932 Lbs**  
Estimated weight concrete only; variations may occur due to product changes and cuts

# 8 | Grill Island

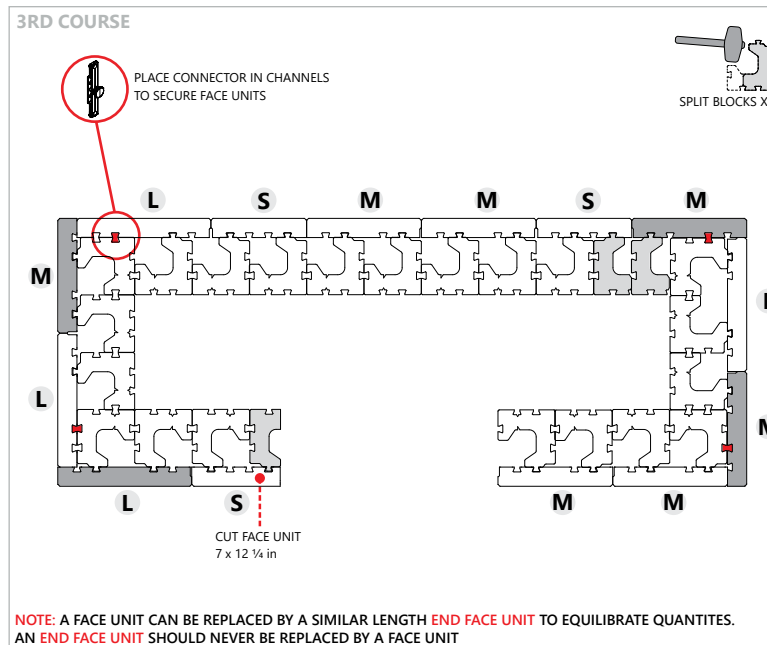
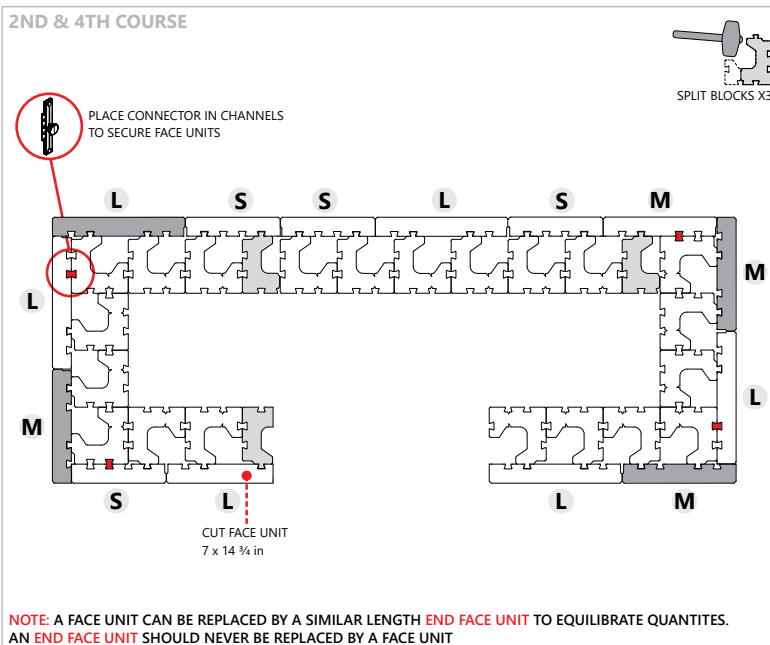
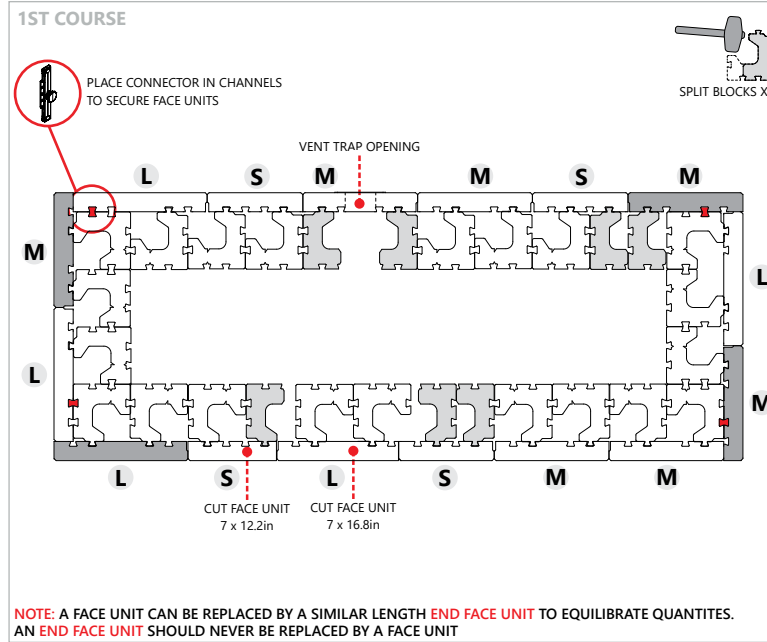
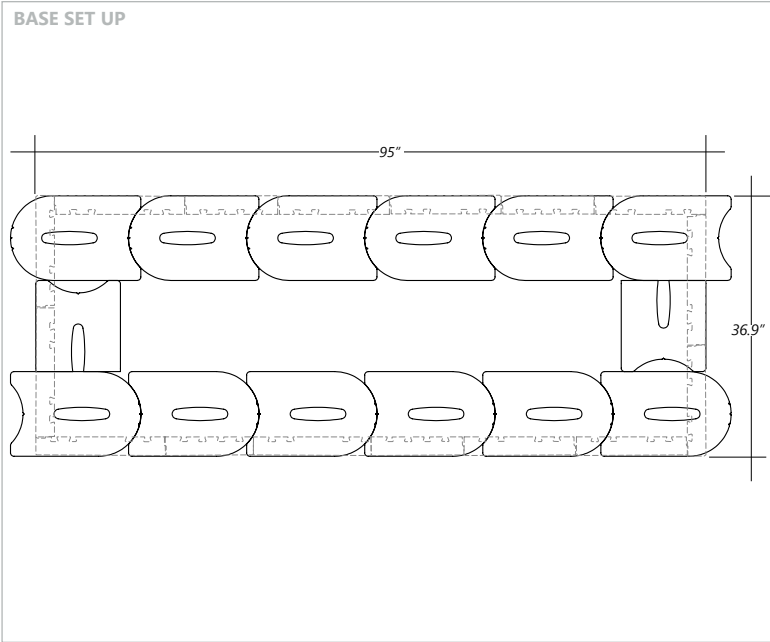

**COMPONENTS**  
NOTE: TANDEM UNITS ARE AVAILABLE IN MULTIPLE FACE STYLES

	<b>SMALL FACE UNIT</b> 7 x 13 13/16 x 2 5/8 in	<b>16x</b>
	<b>SMALL FACE END UNIT</b> 7 x 13 13/16 x 2 5/8 in	<b>0x</b>
	<b>MEDIUM FACE UNIT</b> 7 x 15 13/16 x 2 5/8 in	<b>15x</b>
	<b>MEDIUM FACE END UNIT</b> 7 x 15 13/16 x 2 5/8 in	<b>14x</b>
	<b>LARGE FACE END UNIT</b> 7 x 18 7/16 x 2 5/8 in	<b>25x</b>
<b>TOTAL QTY OF PALLETS</b>		<b>1x</b>
	<b>MODULAR BLOCK</b> 7 1/16 x 7 7/8 x 7 7/8 in	<b>124x</b>
<b>TOTAL QTY OF LAYERS</b>		<b>4x</b>
	<b>UNIVERSAL CONNECTOR</b> 5 3/4 x 1 1/4 x 7/8 in	<b>20x</b>
	<b>CAP</b> 24 x 16 x 2 3/8 in	<b>0x</b>
	<b>U-START UNIT</b> 18 7/16 x 16 x 3 5/8 in	<b>14x</b>

**TOTAL WEIGHT 4932 Lbs**  
Estimated weight concrete only; variations may occur due to product changes and cuts

# 8 | Grill Island

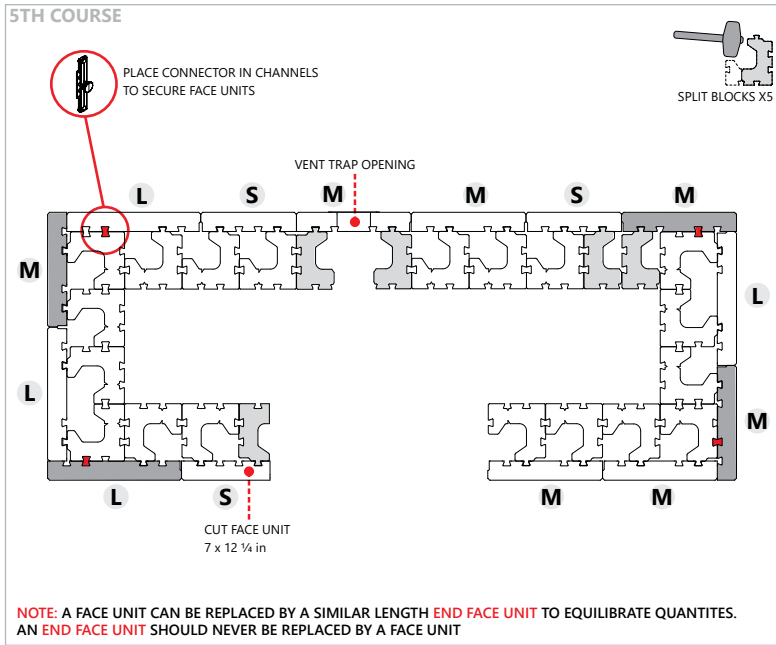

## COMPONENTS

NOTE: TANDEM UNITS ARE AVAILABLE IN MULTIPLE FACE STYLES

- SMALL FACE UNIT**  
7 x 13 1/16 x 2 5/8 in **16x**
- SMALL FACE END UNIT**  
7 x 13 1/16 x 2 5/8 in **0x**
- MEDIUM FACE UNIT**  
7 x 15 1/16 x 2 5/8 in **15x**
- MEDIUM FACE END UNIT**  
7 x 15 1/16 x 2 5/8 in **14x**
- LARGE FACE END UNIT**  
7 x 18 7/16 x 2 5/8 in **25x**

**TOTAL QTY OF PALLETS 1x**

- MODULAR BLOCK**  
7 1/16 x 7 1/8 x 7 1/8 in **124x**

**TOTAL QTY OF LAYERS 4x**

- UNIVERSAL CONNECTOR**  
5 3/4 x 1 1/4 x 1/8 in **20x**

- CAP**  
24 x 16 x 2 3/8 in **0x**

- U-START UNIT**  
18 1/16 x 16 x 3 5/8 in **14x**

**TOTAL WEIGHT 4932 Lbs**  
Estimated weight concrete only; variations may occur due to product changes and cuts

**IMPORTANT:** It is recommended to follow the BBQ manufacturer's specifications for ventilation and clearances. Belgard is not responsible for the conformity, clearances and ventilation. BBQ, countertop and accessories are not included

# 9 | Grill, Bar & Counter Corner Island



FRONT VIEW

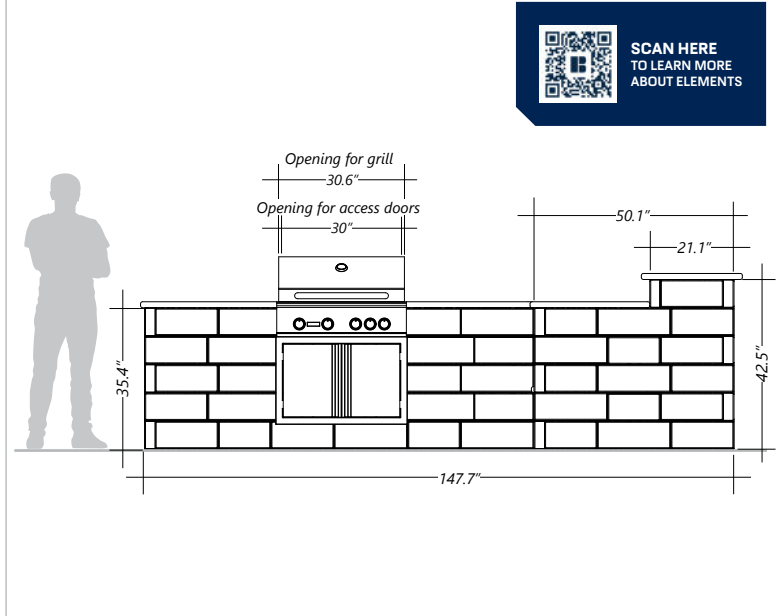

EXPLODED VIEW

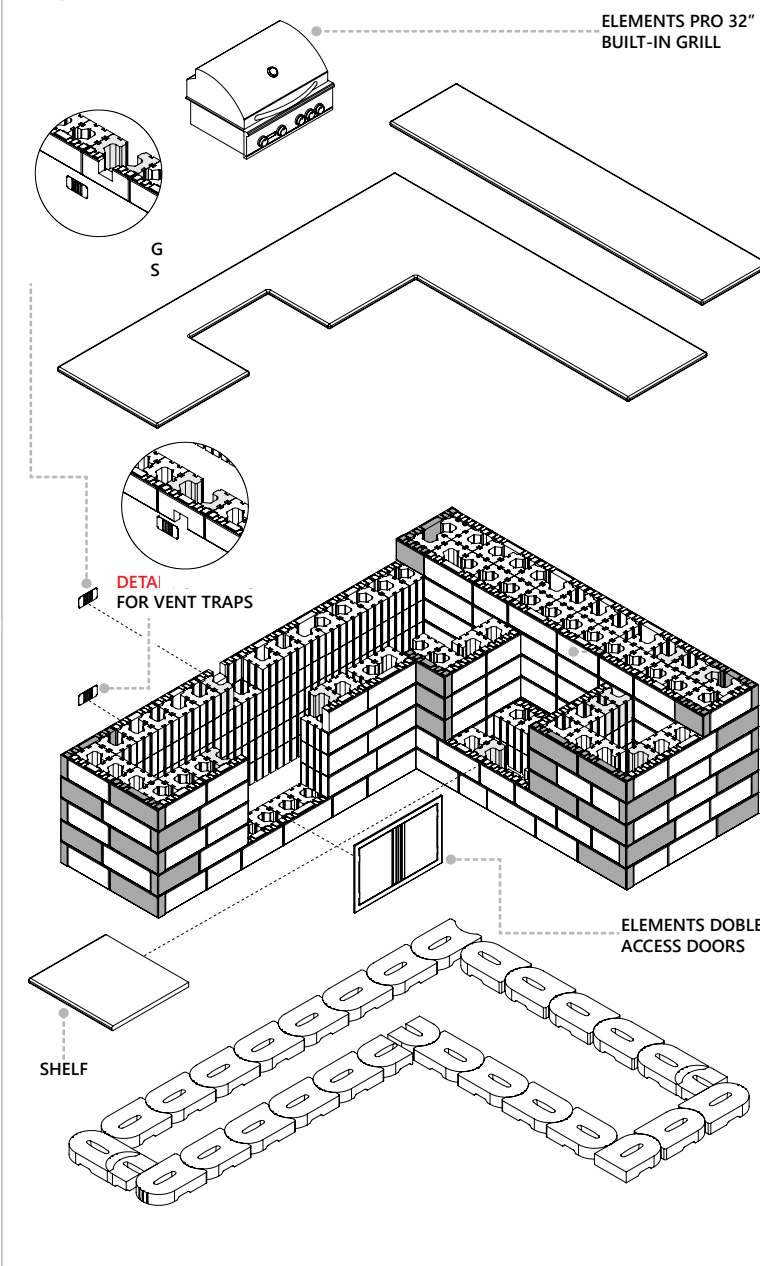

**COMPONENTS**

NOTE: TANDEM UNITS ARE AVAILABLE IN MULTIPLE FACE STYLES

	<b>SMALL FACE UNIT</b> 7 x 13 13/16 x 2 5/8 in	<b>64x</b>
	<b>SMALL FACE END UNIT</b> 7 x 13 13/16 x 2 5/8 in	<b>3x</b>
	<b>MEDIUM FACE UNIT</b> 7 x 15 13/16 x 2 5/8 in	<b>69x</b>
	<b>MEDIUM FACE END UNIT</b> 7 x 15 13/16 x 2 5/8 in	<b>15x</b>
	<b>LARGE FACE END UNIT</b> 7 x 18 7/16 x 2 5/8 in	<b>68x</b>
<b>TOTAL QTY OF PALLETS</b>		<b>3x</b>
	<b>MODULAR BLOCK</b> 7 1/16 x 7 7/8 x 7 7/8 in	<b>391x</b>
<b>TOTAL QTY OF LAYERS</b>		<b>13x</b>
	<b>UNIVERSAL CONNECTOR</b> 5 3/4 x 1 1/4 x 7/8 in	<b>37x</b>
	<b>CAP</b> 24 x 16 x 2 3/8 in	<b>0x</b>
	<b>U-START UNIT</b> 18 7/16 x 16 x 3 5/8 in	<b>36x</b>

**TOTAL WEIGHT 14971 Lbs**  
 Estimated weight concrete only; variations may occur due to product changes and cuts

# 9 | Grill, Bar & Counter Corner Island

## BASE SET UP

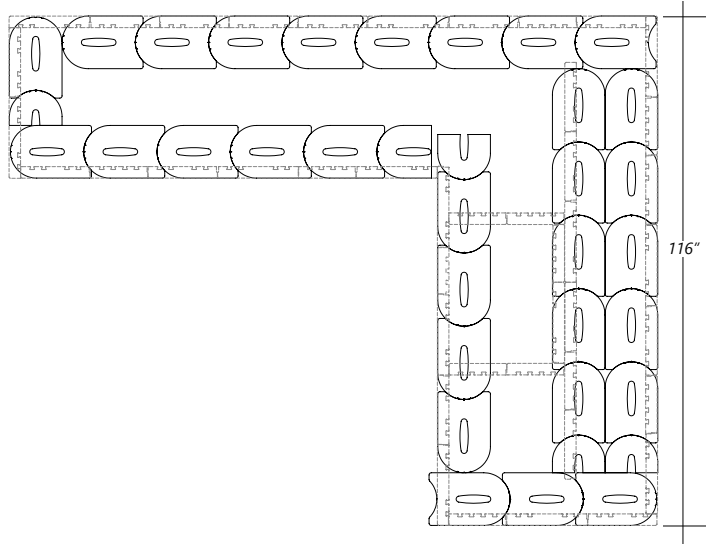

## 1ST COURSE

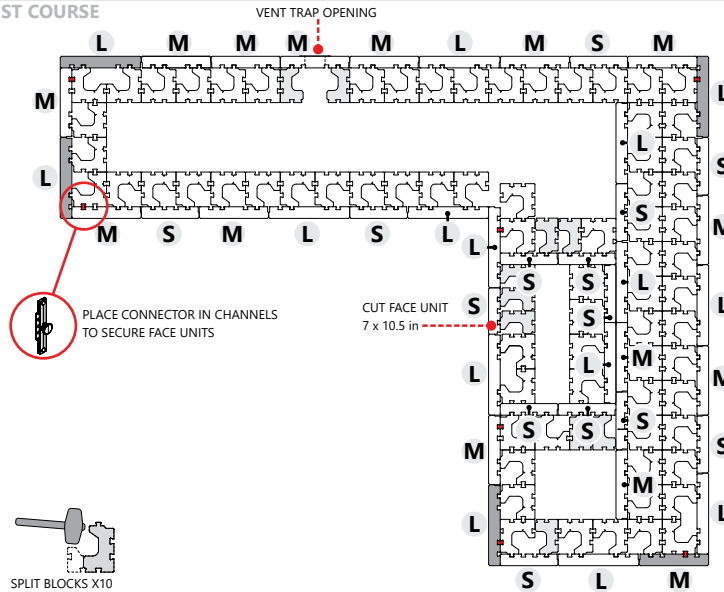

NOTE: A FACE UNIT CAN BE REPLACED BY A SIMILAR LENGTH END FACE UNIT TO EQUILIBRATE QUANTITIES. AN END FACE UNIT SHOULD NEVER BE REPLACED BY A FACE UNIT

## 2ND COURSE

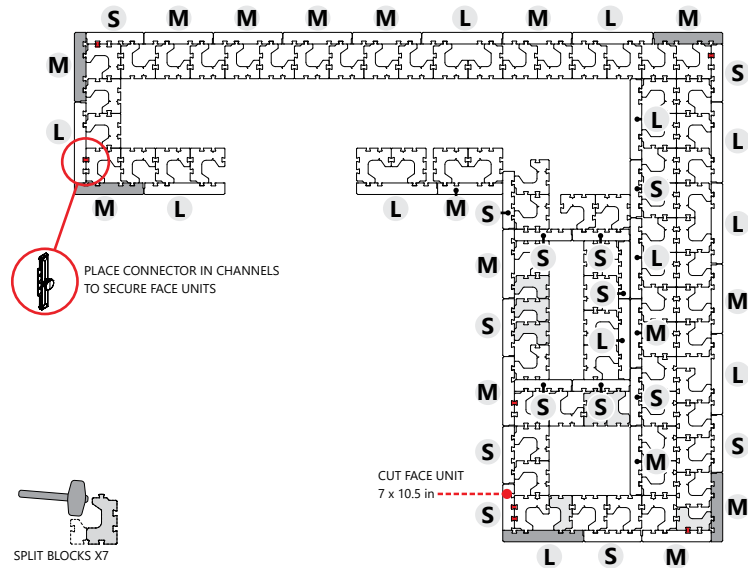

NOTE: A FACE UNIT CAN BE REPLACED BY A SIMILAR LENGTH END FACE UNIT TO EQUILIBRATE QUANTITIES. AN END FACE UNIT SHOULD NEVER BE REPLACED BY A FACE UNIT

## 3RD COURSE

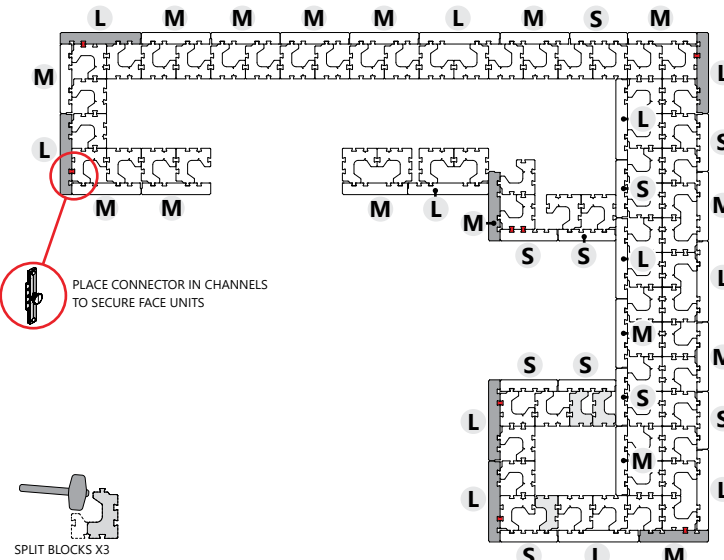

NOTE: A FACE UNIT CAN BE REPLACED BY A SIMILAR LENGTH END FACE UNIT TO EQUILIBRATE QUANTITIES. AN END FACE UNIT SHOULD NEVER BE REPLACED BY A FACE UNIT

## COMPONENTS

NOTE: TANDEM UNITS ARE AVAILABLE IN MULTIPLE FACE STYLES

- SMALL FACE UNIT**  
7 x 13 13/16 x 2 5/8 in **64x**
- SMALL FACE END UNIT**  
7 x 13 13/16 x 2 5/8 in **3x**
- MEDIUM FACE UNIT**  
7 x 15 13/16 x 2 5/8 in **69x**
- MEDIUM FACE END UNIT**  
7 x 15 13/16 x 2 5/8 in **15x**
- LARGE FACE END UNIT**  
7 x 18 7/16 x 2 5/8 in **68x**

**TOTAL QTY OF PALLETS 3x**

- MODULAR BLOCK**  
7 1/16 x 7 7/8 x 7 7/8 in **391x**

**TOTAL QTY OF LAYERS 13x**

- UNIVERSAL CONNECTOR**  
5 3/4 x 1 1/4 x 7/8 in **37x**

- CAP**  
24 x 16 x 2 3/8 in **0x**

- U-START UNIT**  
18 7/16 x 16 x 3 5/8 in **36x**

**TOTAL WEIGHT 14971 Lbs**  
Estimated weight concrete only; variations may occur due to product changes and cuts

**IMPORTANT:** It is recommended to follow the BBQ manufacturer's specifications for ventilation and clearances. Belgard is not responsible for the conformity, clearances and ventilation. BBQ, countertop and accessories are not included

# 9 | Grill, Bar & Counter Corner Island

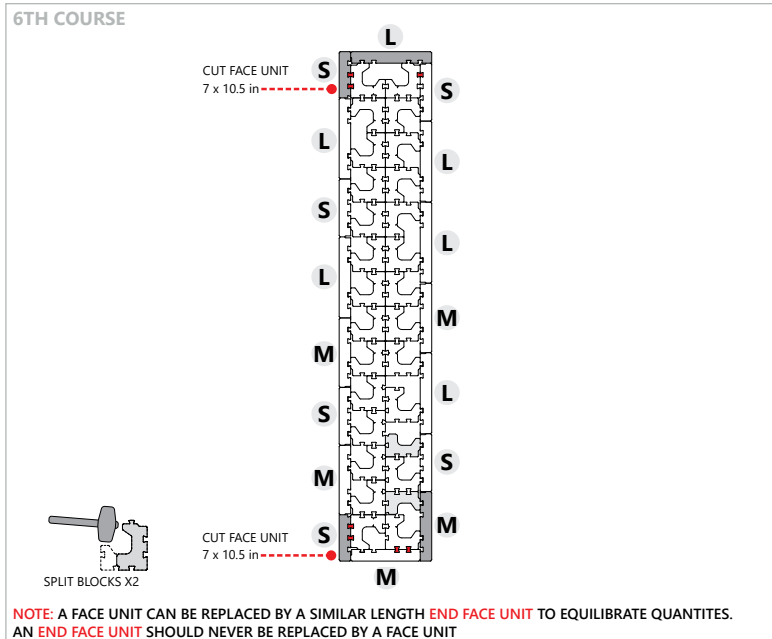
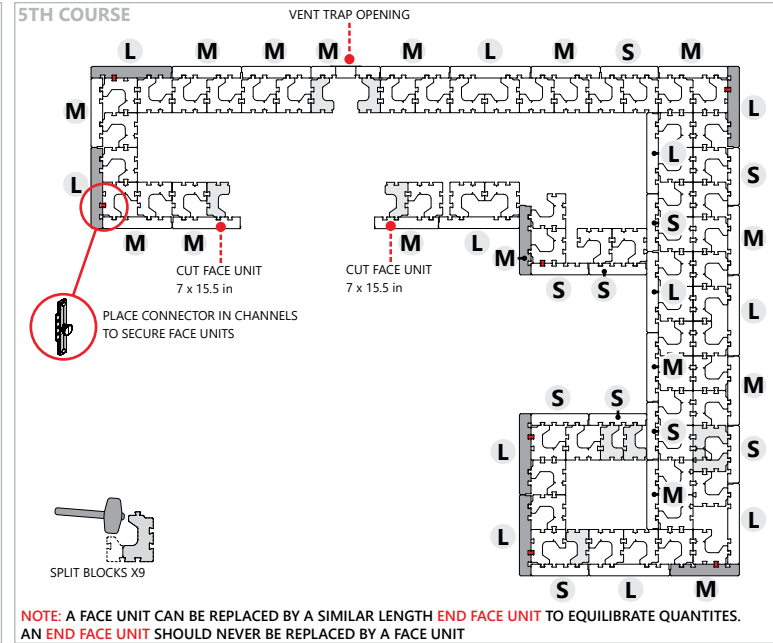
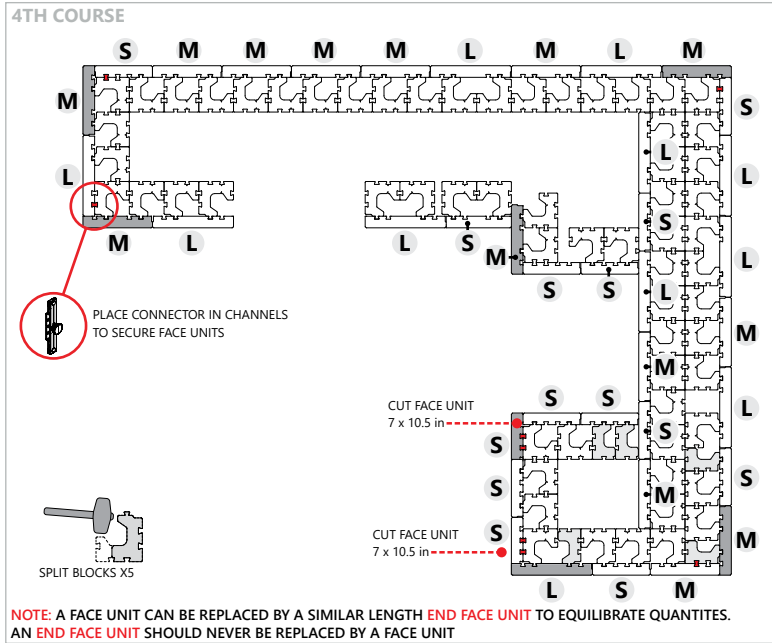

**COMPONENTS**  
NOTE: TANDEM UNITS ARE AVAILABLE IN MULTIPLE FACE STYLES

- SMALL FACE UNIT** 7 x 13 13/16 x 2 3/8 in **64x**
- SMALL FACE END UNIT** 7 x 13 13/16 x 2 3/8 in **3x**
- MEDIUM FACE UNIT** 7 x 15 15/16 x 2 3/8 in **69x**
- MEDIUM FACE END UNIT** 7 x 15 15/16 x 2 3/8 in **15x**
- LARGE FACE END UNIT** 7 x 18 7/16 x 2 3/8 in **68x**

**TOTAL QTY OF PALLETS 3x**

**MODULAR BLOCK** 7 1/16 x 7 7/8 x 7 7/8 in **391x**

**TOTAL QTY OF LAYERS 13x**

**UNIVERSAL CONNECTOR** 5 3/4 x 1 1/4 x 7/8 in **37x**

**CAP** 24 x 16 x 2 3/8 in **0x**

**U-START UNIT** 18 7/16 x 16 x 3 3/8 in **36x**

**TOTAL WEIGHT 14971 Lbs**  
Estimated weight concrete only, variations may occur due to product changes and cuts

**IMPORTANT:** It is recommended to follow the BBQ manufacturer's specifications for ventilation and clearances. Belgard is not responsible for the conformity, clearances and ventilation. BBQ, countertop and accessories are not included

# 10 | Grill, Griddle & Blue Diamond Smoker Corner Island



FRONT VIEW

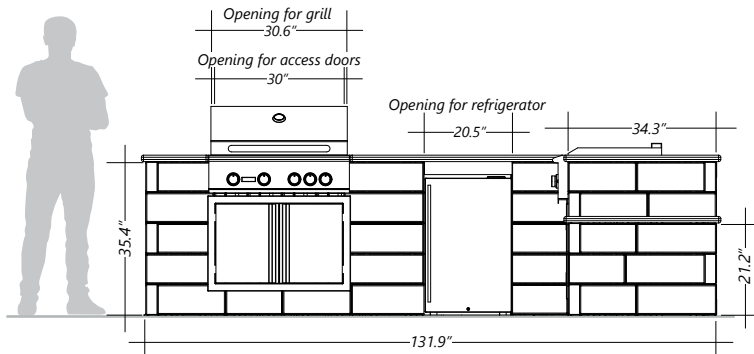
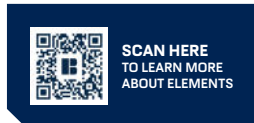

**IMPORTANT:** It is recommended to follow the BBQ manufacturer's specifications for ventilation and clearances. Belgard is not responsible for the conformity, clearances and ventilation. BBQ, countertop and accessories are not included

EXPLODED VIEW

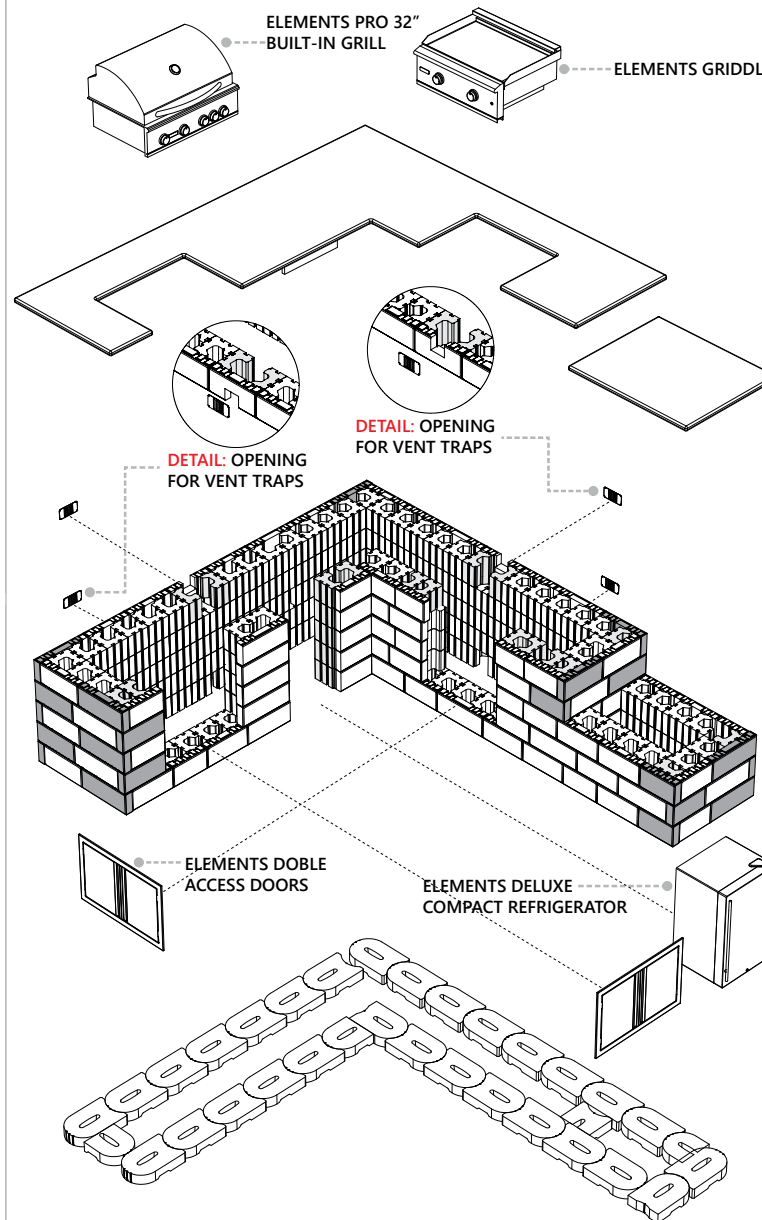

**COMPONENTS**

NOTE: TANDEM UNITS ARE AVAILABLE IN MULTIPLE FACE STYLES

- SMALL FACE UNIT** 39x  
7 x 13 1/16 x 2 3/8 in
- SMALL FACE END UNIT** 4x  
7 x 13 1/16 x 2 3/8 in
- MEDIUM FACE UNIT** 65x  
7 x 15 1/16 x 2 3/8 in
- MEDIUM FACE END UNIT** 13x  
7 x 15 1/16 x 2 3/8 in
- LARGE FACE END UNIT** 34x  
7 x 18 7/16 x 2 3/8 in
- TOTAL QTY OF PALLETS** 3x
- MODULAR BLOCK** 278x  
7 1/16 x 7 7/8 x 7 1/8 in
- TOTAL QTY OF LAYERS** 9x
- UNIVERSAL CONNECTOR** 34x  
5 3/4 x 1 1/4 x 1/8 in
- CAP** 0x  
24 x 16 x 2 3/8 in
- U-START UNIT** 33x  
18 7/16 x 16 x 3 3/8 in

**TOTAL WEIGHT 10978 Lbs**  
 Estimated weight concrete only, variations may occur due to product changes and cuts

# 10 | Grill, Griddle & Blue Diamond Smoker Corner Island



## BASE SET UP

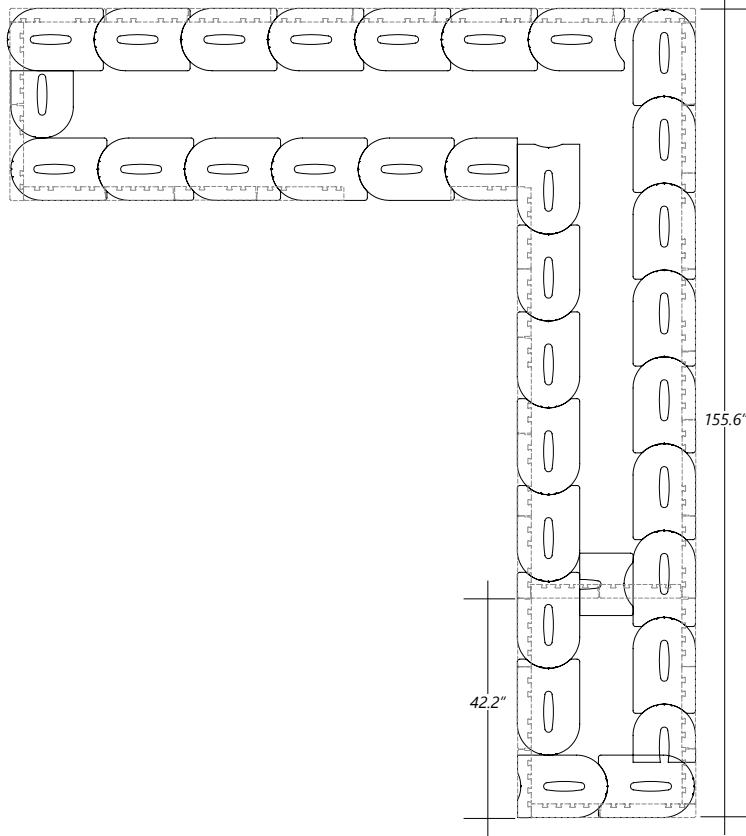

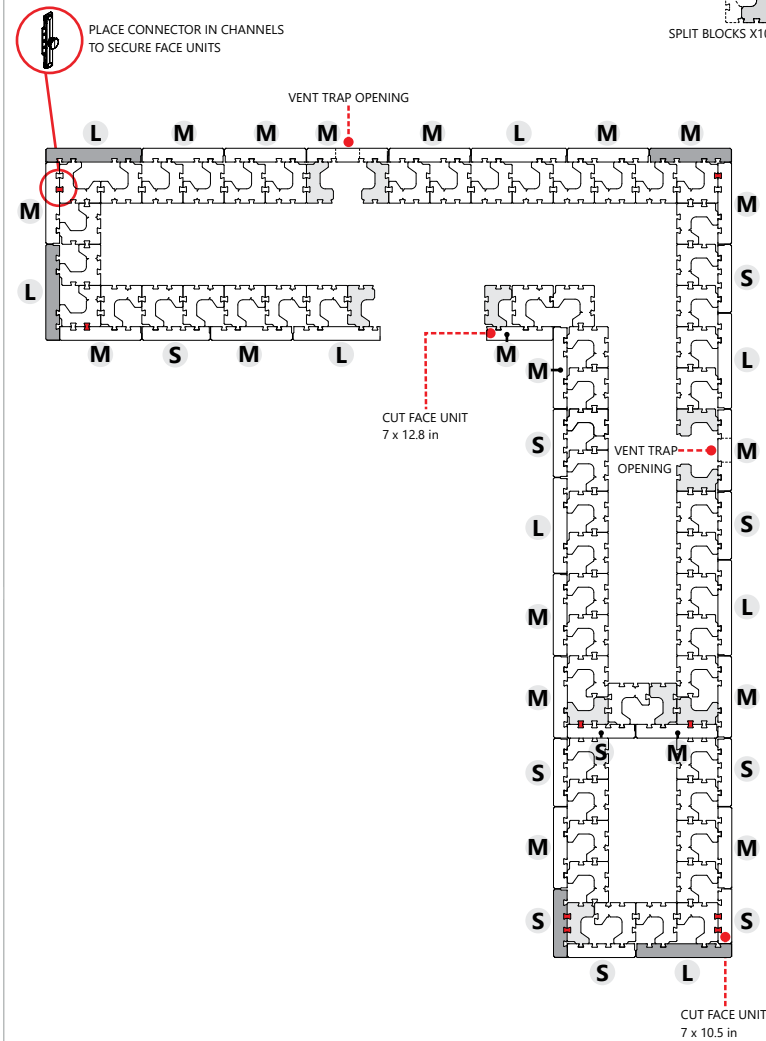

## 1ST COURSE



**NOTE:** A FACE UNIT CAN BE REPLACED BY A SIMILAR LENGTH END FACE UNIT TO EQUILIBRATE QUANTITIES. AN END FACE UNIT SHOULD NEVER BE REPLACED BY A FACE UNIT

## COMPONENTS

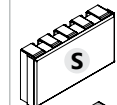
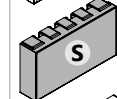
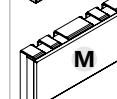
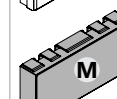
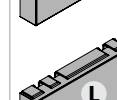
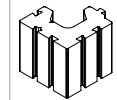
**NOTE:** TANDEM UNITS ARE AVAILABLE IN MULTIPLE FACE STYLES

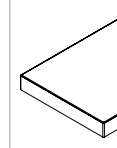
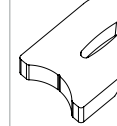
-  **SMALL FACE UNIT**  
7 x 13 1/16 x 2 3/8 in **39x**
-  **SMALL FACE END UNIT**  
7 x 13 1/16 x 2 3/8 in **4x**
-  **MEDIUM FACE UNIT**  
7 x 15 1/16 x 2 3/8 in **65x**
-  **MEDIUM FACE END UNIT**  
7 x 15 1/16 x 2 3/8 in **13x**
-  **LARGE FACE END UNIT**  
7 x 18 7/16 x 2 3/8 in **34x**
- TOTAL QTY OF PALLETS** **3x**
-  **MODULAR BLOCK**  
7 1/16 x 7 1/8 x 7 1/8 in **278x**
- TOTAL QTY OF LAYERS** **9x**
-  **UNIVERSAL CONNECTOR**  
5 3/4 x 1 1/4 x 1/8 in **34x**
-  **CAP**  
24 x 16 x 2 3/8 in **0x**
-  **U-START UNIT**  
18 7/16 x 16 x 3 3/8 in **33x**

**IMPORTANT:** It is recommended to follow the BBQ manufacturer's specifications for ventilation and clearances. Belgard is not responsible for the conformity, clearances and ventilation. BBQ, countertop and accessories are not included

**TOTAL WEIGHT 10978 Lbs**  
Estimated weight concrete only, variations may occur due to product changes and cuts

# 10 | Grill, Griddle & Blue Diamond Smoker Corner Island

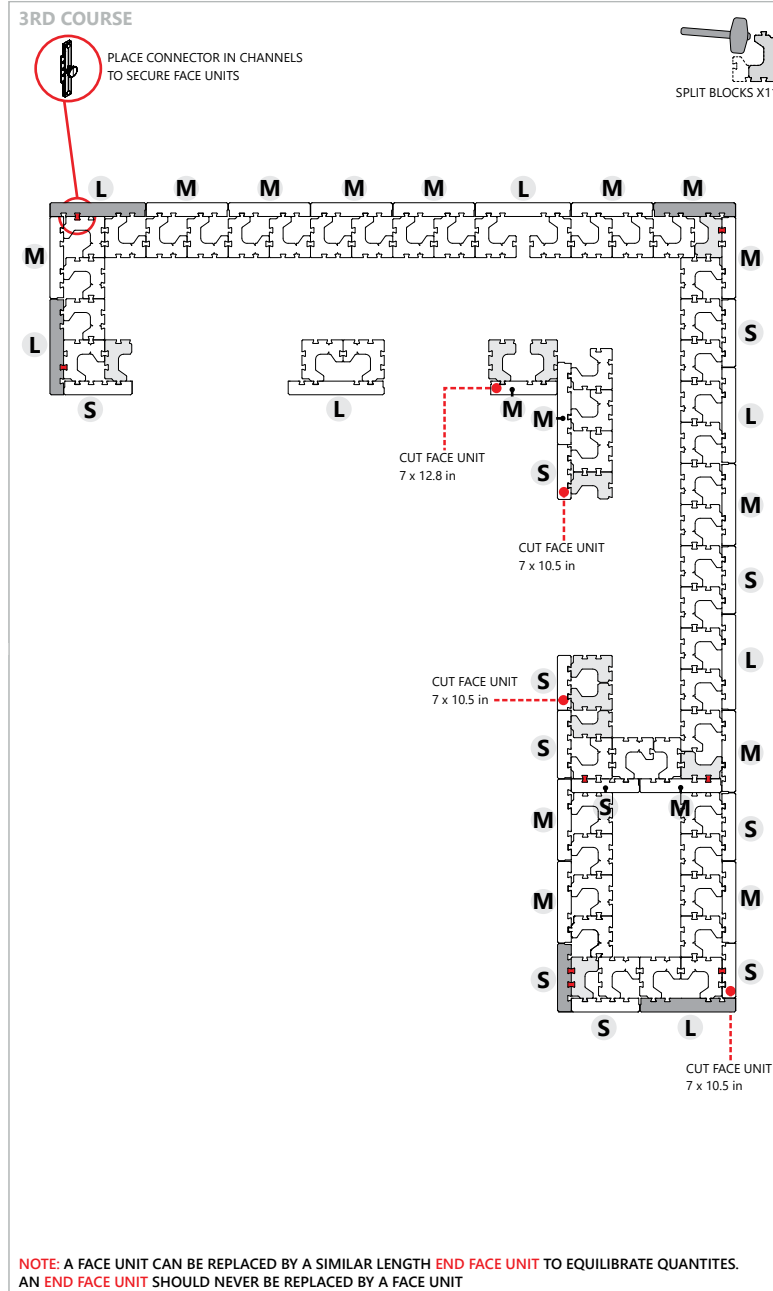
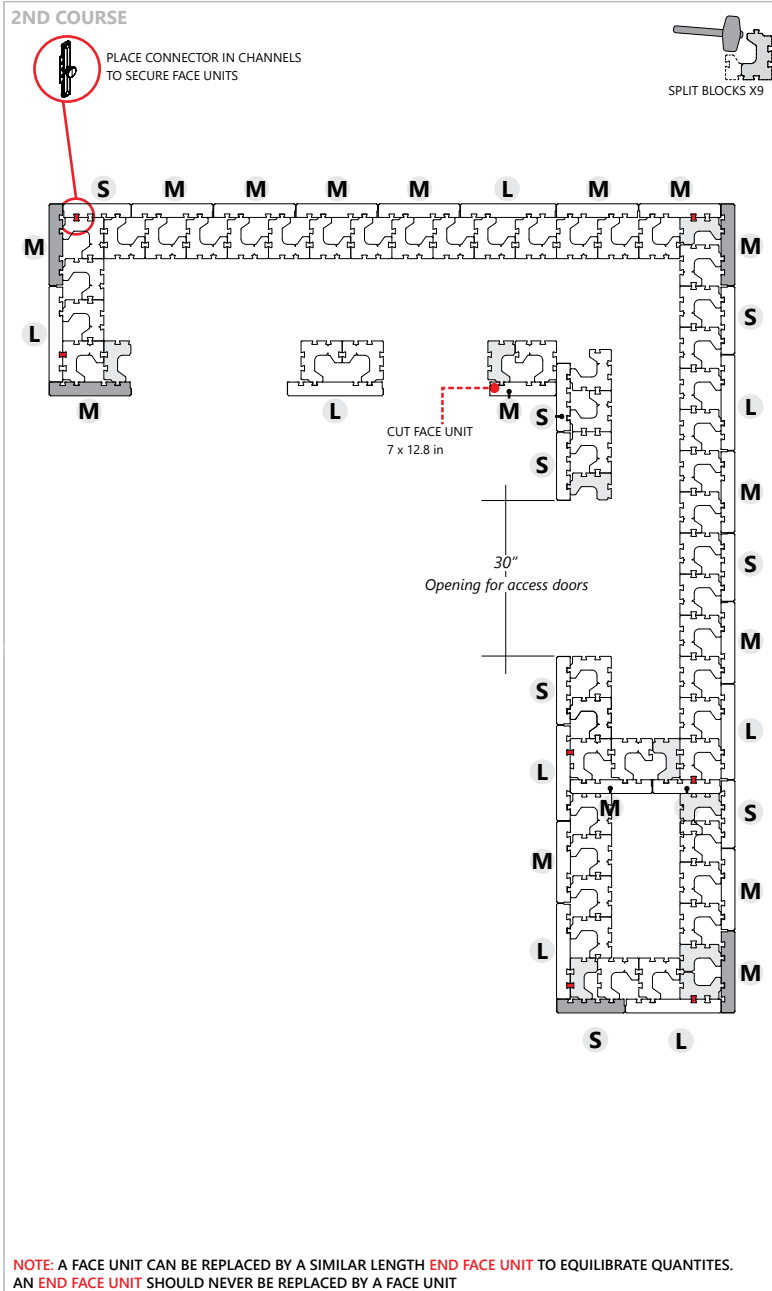

**COMPONENTS**  
NOTE: TANDEM UNITS ARE AVAILABLE IN MULTIPLE FACE STYLES

	<b>SMALL FACE UNIT</b> 7 x 13 1/16 x 2 3/8 in	<b>39x</b>
	<b>SMALL FACE END UNIT</b> 7 x 13 1/16 x 2 3/8 in	<b>4x</b>
	<b>MEDIUM FACE UNIT</b> 7 x 15 1/16 x 2 3/8 in	<b>65x</b>
	<b>MEDIUM FACE END UNIT</b> 7 x 15 1/16 x 2 3/8 in	<b>13x</b>
	<b>LARGE FACE END UNIT</b> 7 x 18 7/16 x 2 3/8 in	<b>34x</b>
<b>TOTAL QTY OF PALLETS</b>		<b>3x</b>
	<b>MODULAR BLOCK</b> 7 1/16 x 7 7/8 x 7 7/8 in	<b>278x</b>
<b>TOTAL QTY OF LAYERS</b>		<b>9x</b>
	<b>UNIVERSAL CONNECTOR</b> 5 3/4 x 1 1/4 x 7/8 in	<b>34x</b>
	<b>CAP</b> 24 x 16 x 2 3/8 in	<b>0x</b>
	<b>U-START UNIT</b> 18 7/16 x 16 x 3 3/8 in	<b>33x</b>

**IMPORTANT:** It is recommended to follow the BBQ manufacturer's specifications for ventilation and clearances. Belgard is not responsible for the conformity, clearances and ventilation. BBQ, countertop and accessories are not included

# 10 | Grill, Griddle & Blue Diamond Smoker Corner Island



## 4TH COURSE

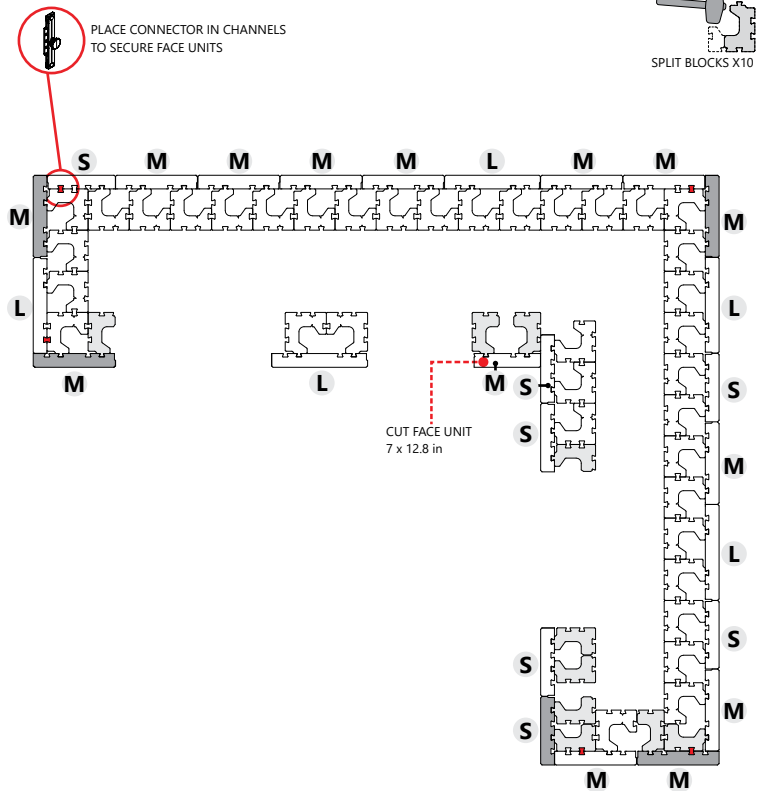

**NOTE:** A FACE UNIT CAN BE REPLACED BY A SIMILAR LENGTH **END FACE UNIT** TO EQUILIBRATE QUANTITIES. AN **END FACE UNIT** SHOULD NEVER BE REPLACED BY A FACE UNIT

**IMPORTANT:** It is recommended to follow the BBQ manufacturer's specifications for ventilation and clearances. Belgard is not responsible for the conformity, clearances and ventilation. BBQ, countertop and accessories are not included

## 5TH COURSE

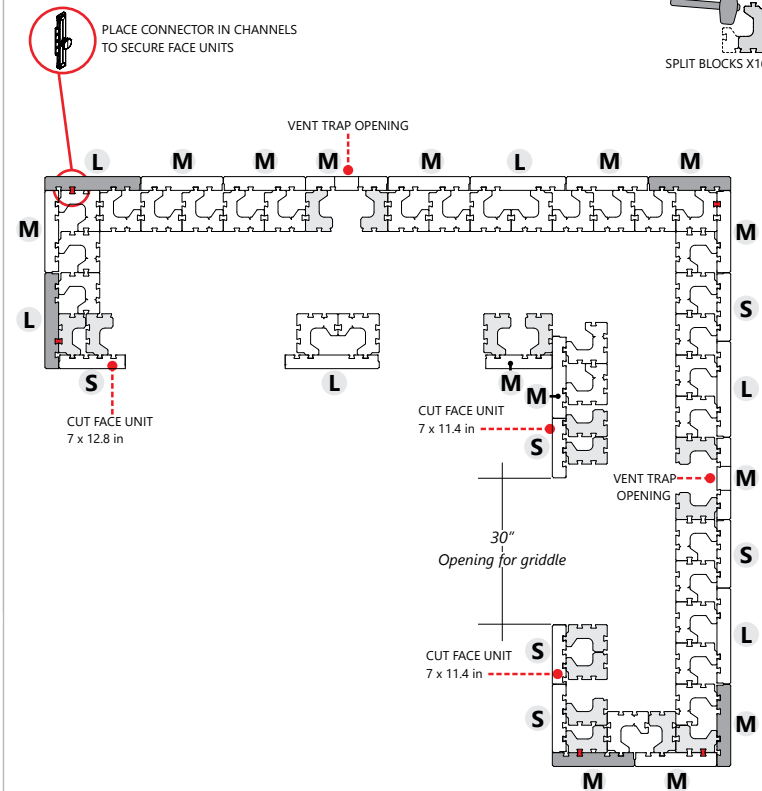

**NOTE:** A FACE UNIT CAN BE REPLACED BY A SIMILAR LENGTH **END FACE UNIT** TO EQUILIBRATE QUANTITIES. AN **END FACE UNIT** SHOULD NEVER BE REPLACED BY A FACE UNIT

## COMPONENTS

**NOTE:** TANDEM UNITS ARE AVAILABLE IN MULTIPLE FACE STYLES

- SMALL FACE UNIT**  
7 x 13 1/16 x 2 3/8 in **39x**
- SMALL FACE END UNIT**  
7 x 13 1/16 x 2 3/8 in **4x**
- MEDIUM FACE UNIT**  
7 x 15 1/16 x 2 3/8 in **65x**
- MEDIUM FACE END UNIT**  
7 x 15 1/16 x 2 3/8 in **13x**
- LARGE FACE END UNIT**  
7 x 18 7/16 x 2 3/8 in **34x**
- TOTAL QTY OF PALLETS** **3x**
- MODULAR BLOCK**  
7 1/16 x 7 7/8 x 7 7/8 in **278x**
- TOTAL QTY OF LAYERS** **9x**
- UNIVERSAL CONNECTOR**  
5 3/4 x 1 1/4 x 7/8 in **34x**
- CAP**  
24 x 16 x 2 3/8 in **0x**
- U-START UNIT**  
18 7/16 x 16 x 3 3/8 in **33x**

**TOTAL WEIGHT 10978 Lbs**  
Estimated weight concrete only; variations may occur due to product changes and cuts

# 11 | Fire Bowls & Columns



FRONT VIEW

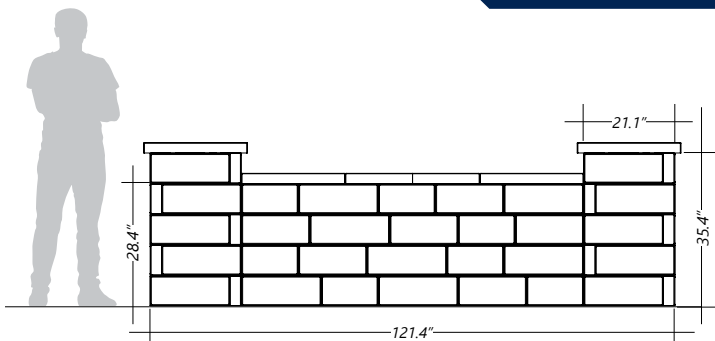
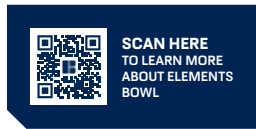

**IMPORTANT:** It is recommended to follow the Stone Fire and Water Bowl manufacturer's specifications. Belgard is not responsible for the conformity of connections and clearances. Plumbing kit and accessories are not included.

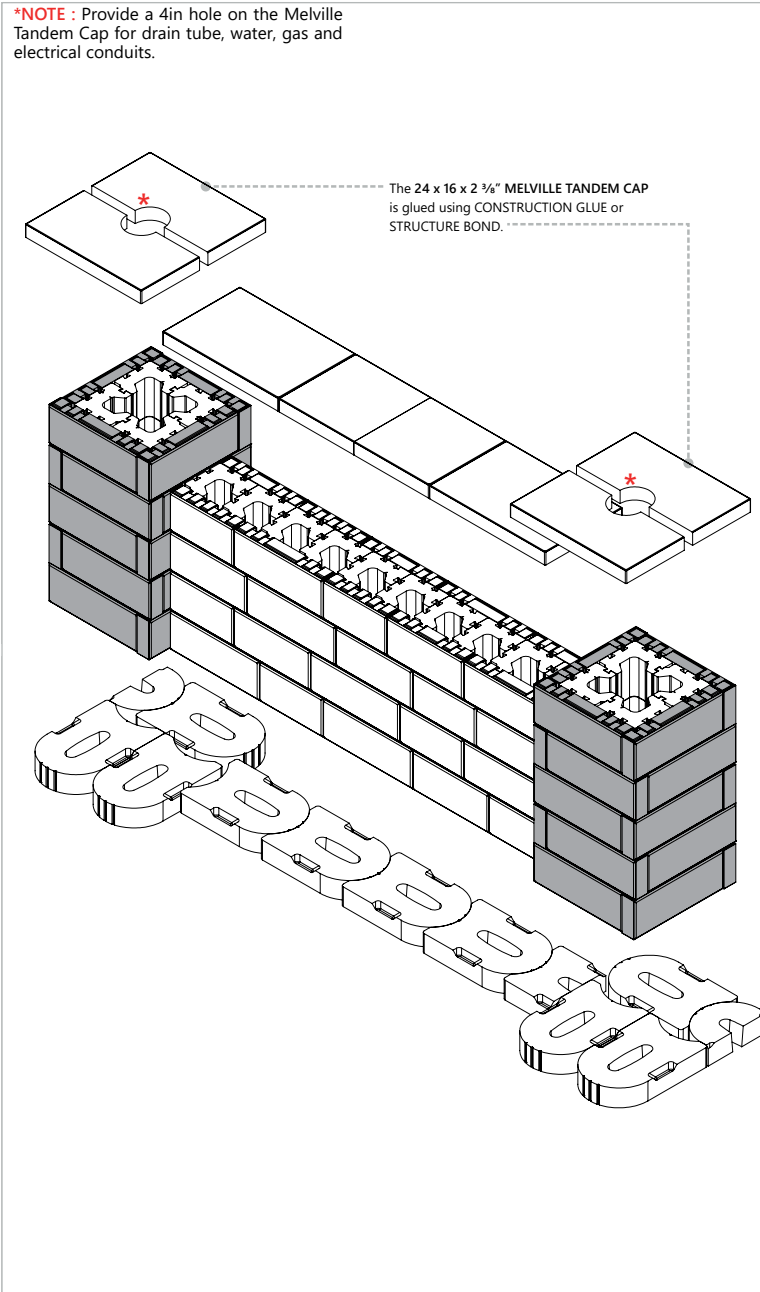

### COMPONENTS

**NOTE:** TANDEM UNITS ARE AVAILABLE IN MULTIPLE FACE STYLES

- SMALL FACE UNIT** 7 x 13 13/16 x 2 5/8 in **13x**
- SMALL FACE END UNIT** 7 x 13 13/16 x 2 5/8 in **0x**
- MEDIUM FACE UNIT** 7 x 15 13/16 x 2 5/8 in **14x**
- MEDIUM FACE END UNIT** 7 x 15 13/16 x 2 5/8 in **0x**
- LARGE FACE END UNIT** 7 x 18 7/16 x 2 5/8 in **53x**
- TOTAL QTY OF PALLETS** **2x**  
\*Use the Tandem column kit where available.
- MODULAR BLOCK** 7 1/8 x 7 7/8 x 7 7/8 in **80x**
- TOTAL QTY OF LAYERS** **3x**
- UNIVERSAL CONNECTOR** 5 3/4 x 1 1/4 x 7/8 in **120x**
- CAP** 24 x 16 x 2 3/4 in **8x**
- U-START UNIT** 18 7/16 x 16 x 3 5/8 in **13x**

**TOTAL WEIGHT 4928 Lbs**  
Estimated weight concrete only; variations may occur due to product changes and cuts

# 11 | Fire Bowls & Columns

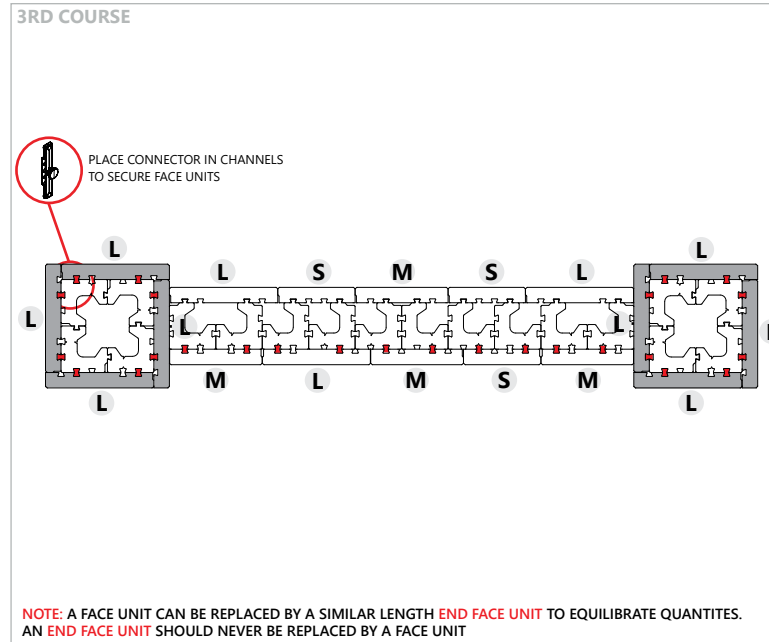
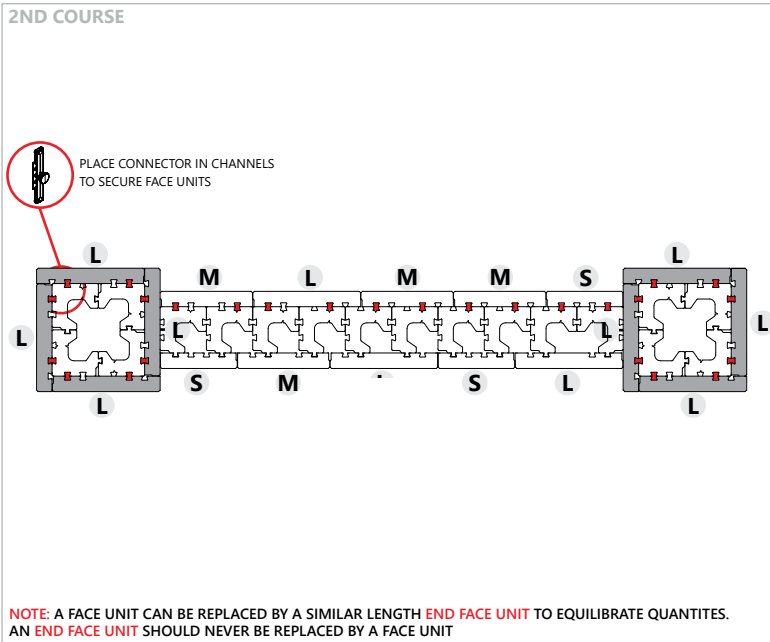
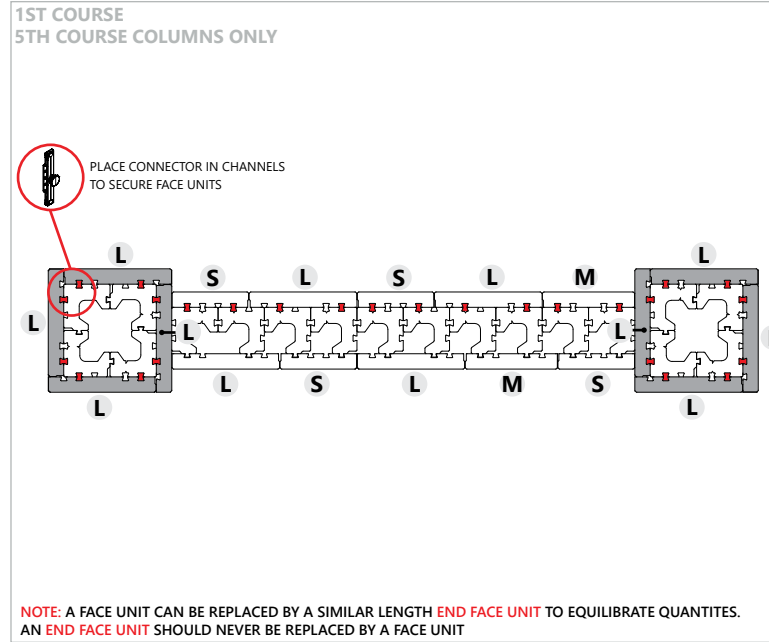
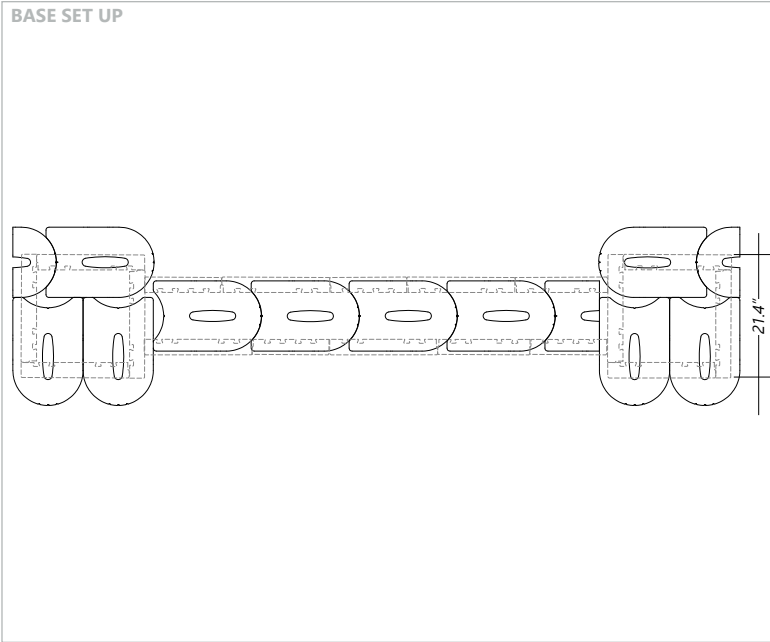

**COMPONENTS**  
NOTE: TANDEM UNITS ARE AVAILABLE IN MULTIPLE FACE STYLES

- SMALL FACE UNIT**  
7 x 13 13/16 x 2 3/8 in **13x**
- SMALL FACE END UNIT**  
7 x 13 13/16 x 2 3/8 in **0x**
- MEDIUM FACE UNIT**  
7 x 15 13/16 x 2 3/8 in **14x**
- MEDIUM FACE END UNIT**  
7 x 15 13/16 x 2 3/8 in **0x**
- LARGE FACE END UNIT**  
7 x 18 7/16 x 2 3/8 in **53x**

**TOTAL QTY OF PALLETS 2x**  
\*Use the Tandem column kit where available.

- MODULAR BLOCK**  
7 1/16 x 7 7/8 x 7 7/8 in **80x**

**TOTAL QTY OF LAYERS 3x**

- UNIVERSAL CONNECTOR**  
5 3/4 x 1 1/4 x 7/8 in **120x**

- CAP**  
24 x 16 x 2 3/8 in **8x**

- U-START UNIT**  
18 7/16 x 16 x 3 3/8 in **13x**

**TOTAL WEIGHT 4928 Lbs**  
Estimated weight concrete only; variations may occur due to product changes and cuts

**IMPORTANT:** It is recommended to follow the Stone Fire and Water Bowl manufacturer's specifications. Belgard is not responsible for the conformity of connections and clearances. Plumbing kit and accessories are not included.

# 11 | Fire Bowls & Columns

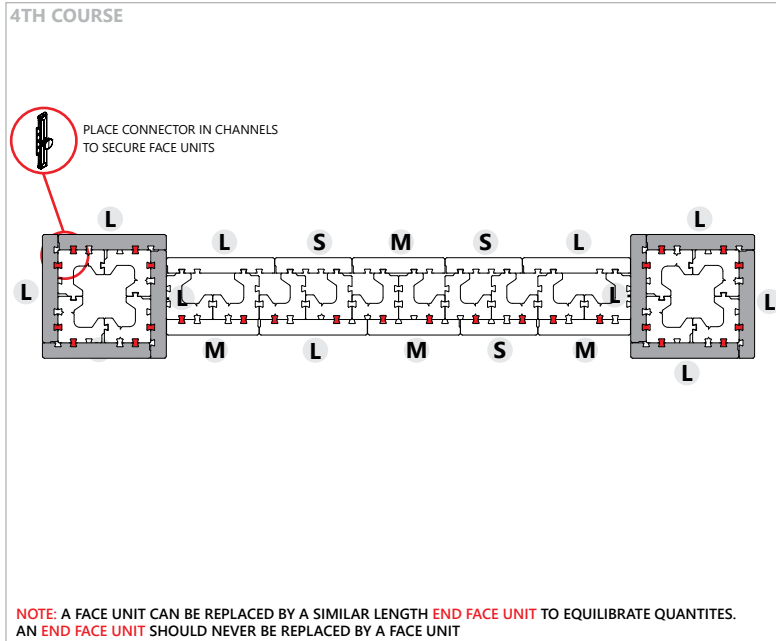

COMPONENTS		
NOTE: TANDEM UNITS ARE AVAILABLE IN MULTIPLE FACE STYLES		
	<b>SMALL FACE UNIT</b> 7 x 13 13/16 x 2 3/8 in	<b>13x</b>
	<b>SMALL FACE END UNIT</b> 7 x 13 13/16 x 2 3/8 in	<b>0x</b>
	<b>MEDIUM FACE UNIT</b> 7 x 15 13/16 x 2 3/8 in	<b>14x</b>
	<b>MEDIUM FACE END UNIT</b> 7 x 15 13/16 x 2 3/8 in	<b>0x</b>
	<b>LARGE FACE END UNIT</b> 7 x 18 7/16 x 2 3/8 in	<b>53x</b>
<b>TOTAL QTY OF PALLETS</b>		<b>2x</b>
*Use the Tandem column kit where available.		
	<b>MODULAR BLOCK</b> 7 1/16 x 7 1/8 x 7 1/8 in	<b>80x</b>
<b>TOTAL QTY OF LAYERS</b>		<b>3x</b>
	<b>UNIVERSAL CONNECTOR</b> 5 3/4 x 1 1/4 x 1/8 in	<b>120x</b>
	<b>CAP</b> 24 x 16 x 2 3/8 in	<b>8x</b>
	<b>U-START UNIT</b> 18 7/16 x 16 x 3 5/8 in	<b>13x</b>
<b>TOTAL WEIGHT</b>		<b>4928 Lbs</b>
Estimated weight concrete only; variations may occur due to product changes and cuts		

**IMPORTANT:** It is recommended to follow the Stone Fire and Water Bowl manufacturer's specifications. Belgard is not responsible for the conformity of connections and clearances. Plumbing kit and accessories are not included.

# 12 | Waterfall

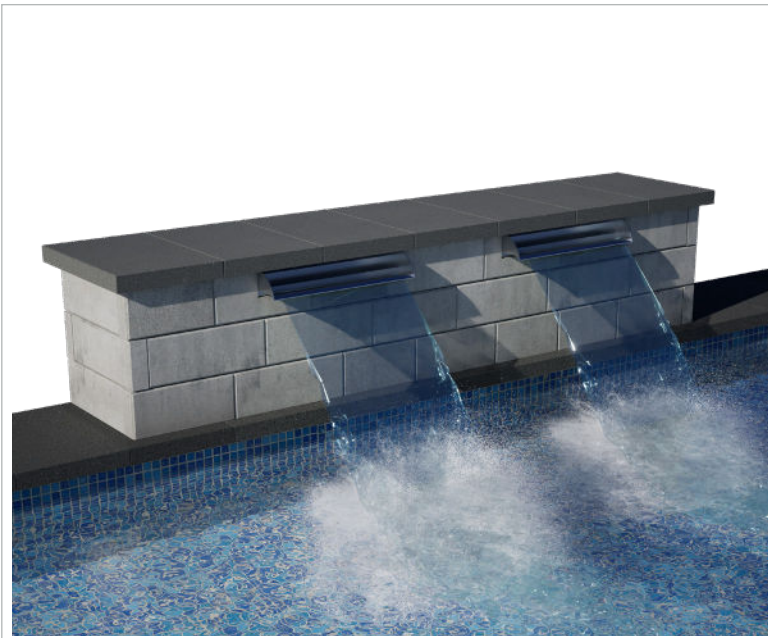

FRONT VIEW

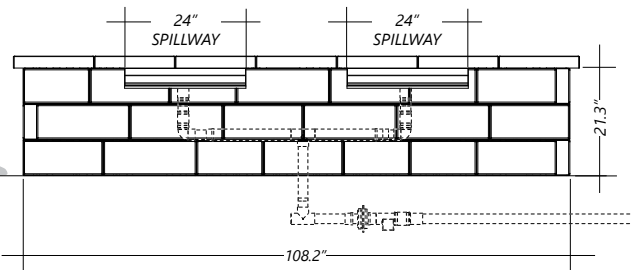
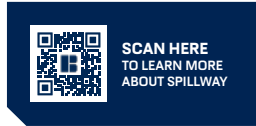

**IMPORTANT:** It is recommended to follow the spillway manufacturer's specifications. Belgard is not responsible for the conformity of connections and clearances. Plumbing kit and accessories are not included.

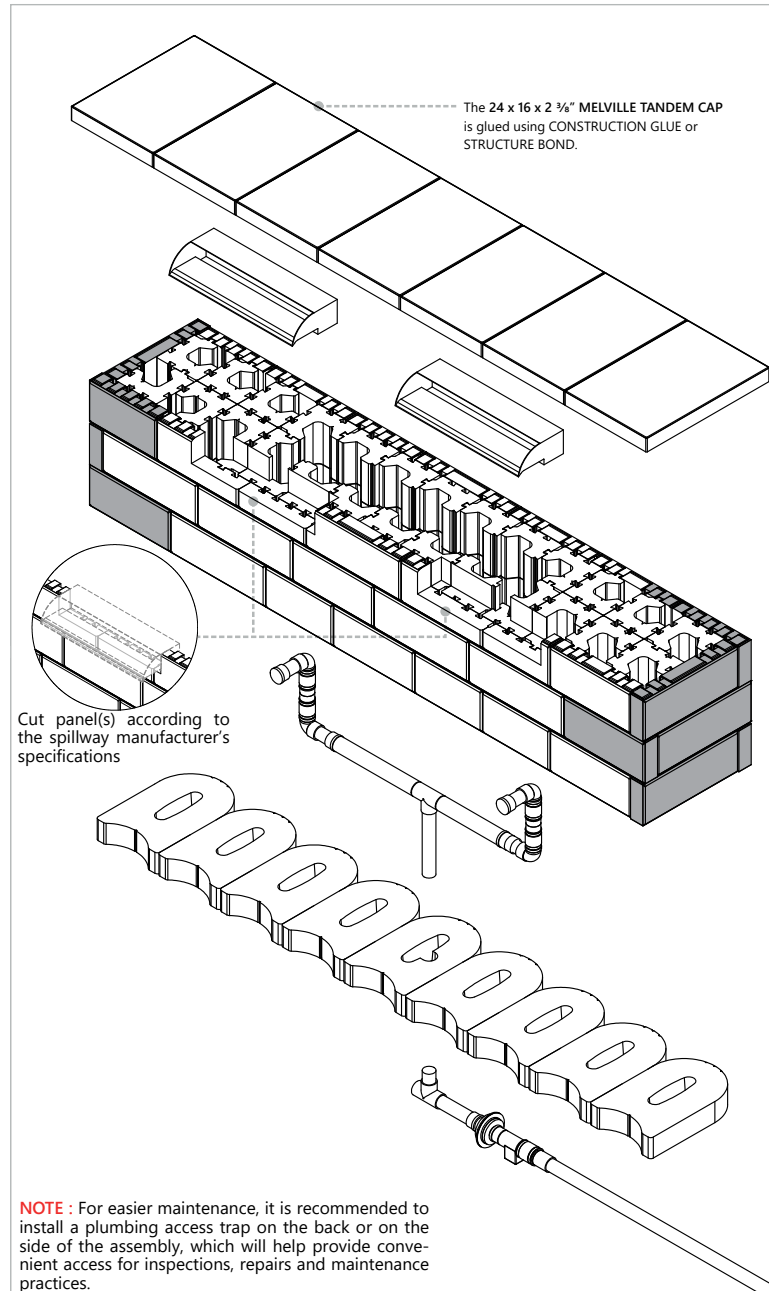

### COMPONENTS

**NOTE:** TANDEM UNITS ARE AVAILABLE IN MULTIPLE FACE STYLES

- SMALL FACE UNIT** 7 x 13 13/16 x 2 3/8 in **13x**
- SMALL FACE END UNIT** 7 x 13 13/16 x 2 3/8 in **2x**
- MEDIUM FACE UNIT** 7 x 15 13/16 x 2 3/8 in **15x**
- MEDIUM FACE END UNIT** 7 x 15 13/16 x 2 3/8 in **2x**
- LARGE FACE END UNIT** 7 x 18 7/16 x 2 3/8 in **16x**
- TOTAL QTY OF PALLETS** **1x**
- MODULAR BLOCK** 7 1/16 x 7 7/16 x 7 7/16 in **78x**
- TOTAL QTY OF LAYERS** **3x**
- UNIVERSAL CONNECTOR** 5 3/4 x 1 1/4 x 7/8 in **45x**
- CAP** 24 x 16 x 2 3/8 in **7x**
- U-START UNIT** 18 7/16 x 16 x 3 3/8 in **9x**

**TOTAL WEIGHT 3684 Lbs**  
 Estimated weight concrete only; variations may occur due to product changes and cuts

# 12 | Waterfall

### BASE SET UP

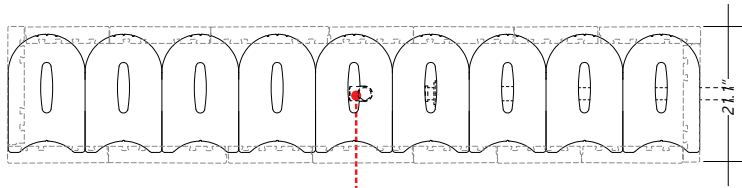

ENSURE ADEQUATE CLEARANCE FOR SPILLWAY INSTALLATION

### 1ST COURSE

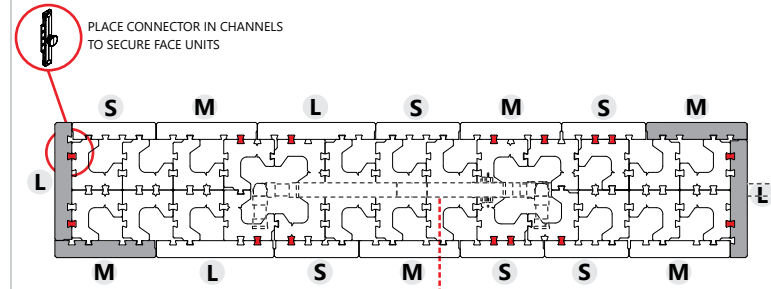

PLACE CONNECTOR IN CHANNELS TO SECURE FACE UNITS

ENSURE ADEQUATE CLEARANCE FOR SPILLWAY INSTALLATION

**NOTE:** A FACE UNIT CAN BE REPLACED BY A SIMILAR LENGTH END FACE UNIT TO EQUILIBRATE QUANTITIES. AN END FACE UNIT SHOULD NEVER BE REPLACED BY A FACE UNIT

### 2ND COURSE

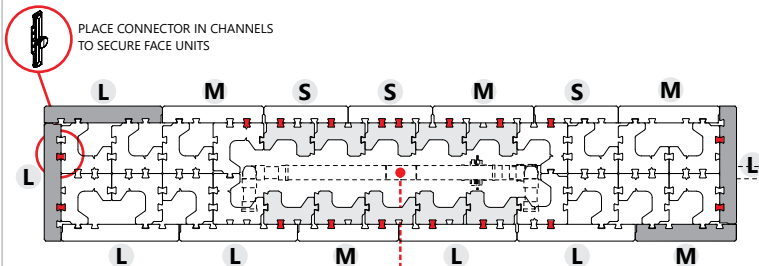
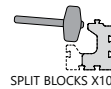

PLACE CONNECTOR IN CHANNELS TO SECURE FACE UNITS

ENSURE ADEQUATE CLEARANCE FOR SPILLWAY INSTALLATION

**NOTE:** A FACE UNIT CAN BE REPLACED BY A SIMILAR LENGTH END FACE UNIT TO EQUILIBRATE QUANTITIES. AN END FACE UNIT SHOULD NEVER BE REPLACED BY A FACE UNIT

### 3RD COURSE

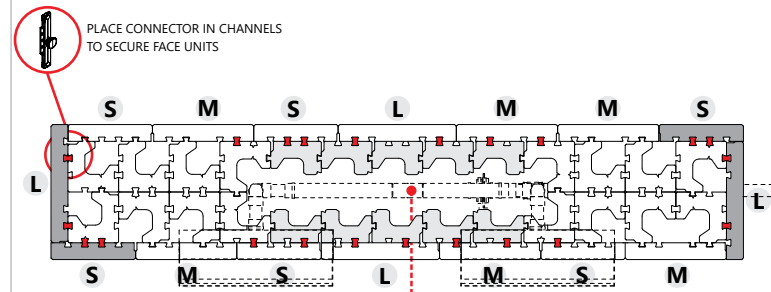
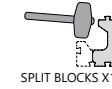

PLACE CONNECTOR IN CHANNELS TO SECURE FACE UNITS

ENSURE ADEQUATE CLEARANCE FOR SPILLWAY INSTALLATION

**NOTE:** A FACE UNIT CAN BE REPLACED BY A SIMILAR LENGTH END FACE UNIT TO EQUILIBRATE QUANTITIES. AN END FACE UNIT SHOULD NEVER BE REPLACED BY A FACE UNIT

### COMPONENTS

**NOTE:** TANDEM UNITS ARE AVAILABLE IN MULTIPLE FACE STYLES

	<b>SMALL FACE UNIT</b> 7 x 13 13/16 x 2 3/8 in	<b>13x</b>
	<b>SMALL FACE END UNIT</b> 7 x 13 13/16 x 2 3/8 in	<b>2x</b>
	<b>MEDIUM FACE UNIT</b> 7 x 15 13/16 x 2 3/8 in	<b>15x</b>
	<b>MEDIUM FACE END UNIT</b> 7 x 15 13/16 x 2 3/8 in	<b>2x</b>
	<b>LARGE FACE END UNIT</b> 7 x 18 7/16 x 2 3/8 in	<b>16x</b>

**TOTAL QTY OF PALLETS 1x**

	<b>MODULAR BLOCK</b> 7 1/16 x 7 7/8 x 7 7/8 in	<b>78x</b>
--	---	------------

**TOTAL QTY OF LAYERS 3x**

	<b>UNIVERSAL CONNECTOR</b> 5 3/4 x 1 1/4 x 7/8 in	<b>45x</b>
--	--	------------

	<b>CAP</b> 24 x 16 x 2 3/8 in	<b>7x</b>
--	----------------------------------	-----------

	<b>U-START UNIT</b> 18 7/16 x 16 x 3 3/8 in	<b>9x</b>
--	--	-----------

**TOTAL WEIGHT 3684 Lbs**  
Estimated weight concrete only; variations may occur due to product changes and cuts

**IMPORTANT:** It is recommended to follow the spillway manufacturer's specifications. Belgard is not responsible for the conformity of connections and clearances. Plumbing kit and accessories are not included.

# 13 | Steps With Planters

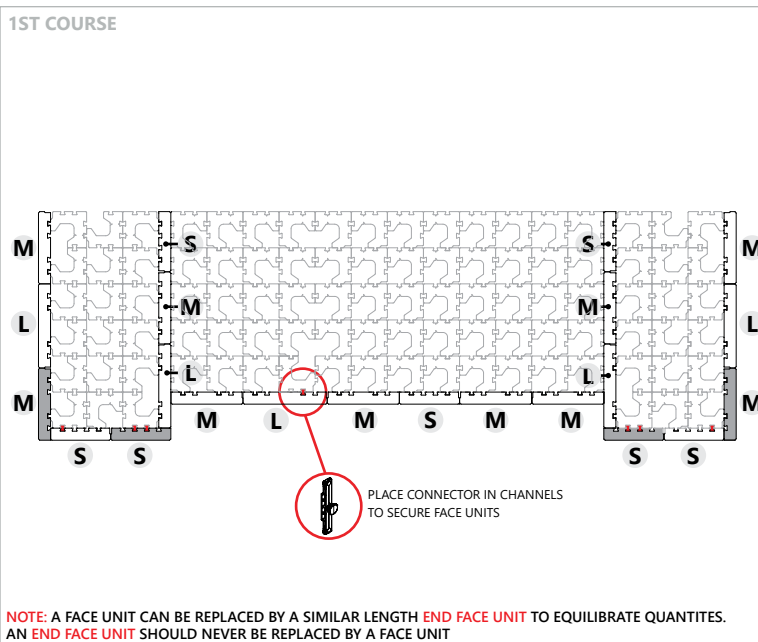
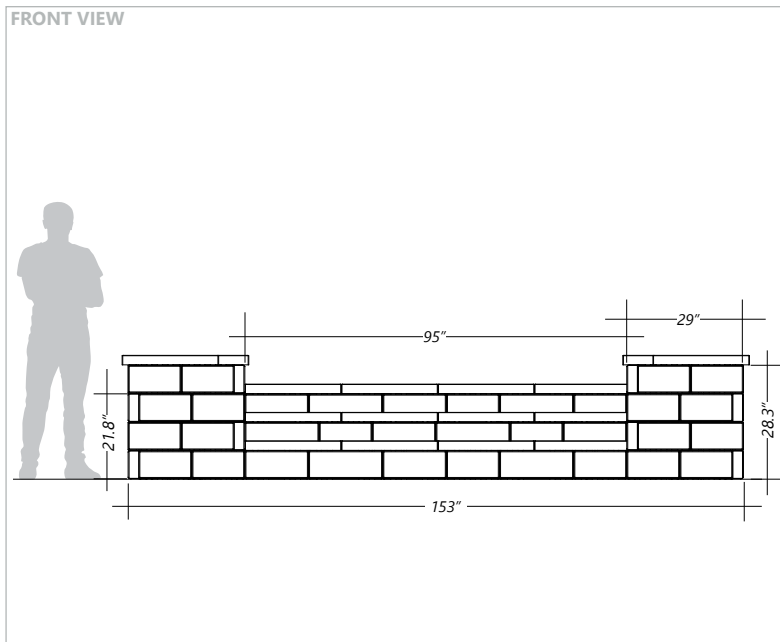
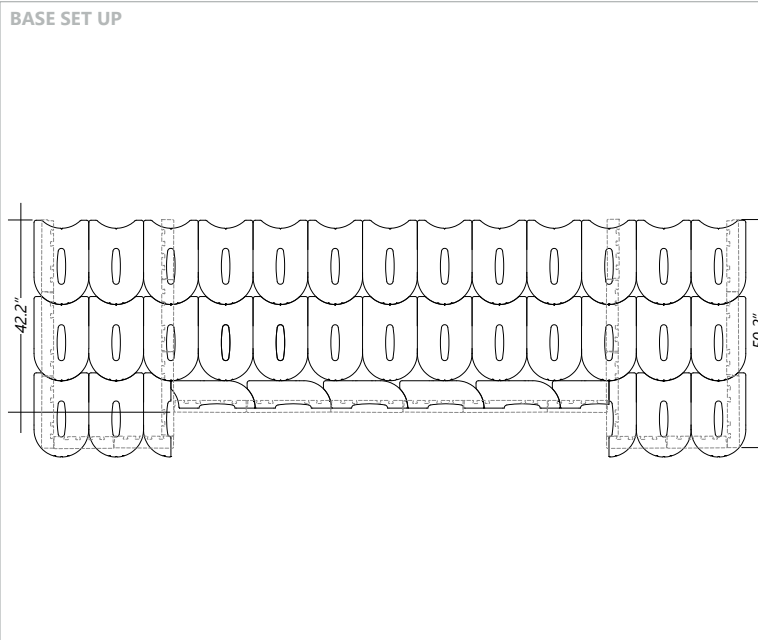

**COMPONENTS**  
NOTE: TANDEM UNITS ARE AVAILABLE IN MULTIPLE FACE STYLES

	<b>SMALL FACE UNIT</b> 7 x 13 13/16 x 2 5/8 in	<b>22x</b>
	<b>SMALL FACE END UNIT</b> 7 x 13 13/16 x 2 5/8 in	<b>8x</b>
	<b>MEDIUM FACE UNIT</b> 7 x 15 13/16 x 2 5/8 in	<b>24x</b>
	<b>MEDIUM FACE END UNIT</b> 7 x 15 13/16 x 2 5/8 in	<b>6x</b>
	<b>LARGE FACE END UNIT</b> 7 x 18 7/16 x 2 5/8 in	<b>23x</b>
<b>TOTAL QTY OF PALLETS</b>		<b>1x</b>
	<b>MODULAR BLOCK</b> 7 1/16 x 7 7/8 x 7 7/8 in	<b>228x</b>
<b>TOTAL QTY OF LAYERS</b>		<b>8x</b>
	<b>UNIVERSAL CONNECTOR</b> 5 3/4 x 1 1/4 x 7/8 in	<b>102x</b>
	<b>CAP</b> 24 x 16 x 2 3/8 in	<b>24x</b>
	<b>U-START UNIT</b> 18 7/16 x 16 x 3 3/8 in	<b>0x</b>

**TOTAL WEIGHT 10384 Lbs**  
Estimated weight concrete only, variations may occur due to product changes and cuts

# 13 | Steps With Planters

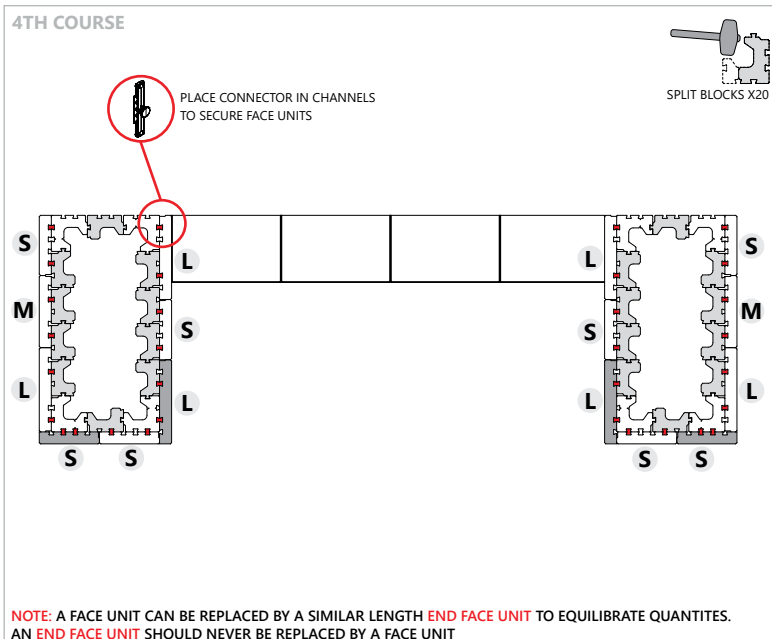
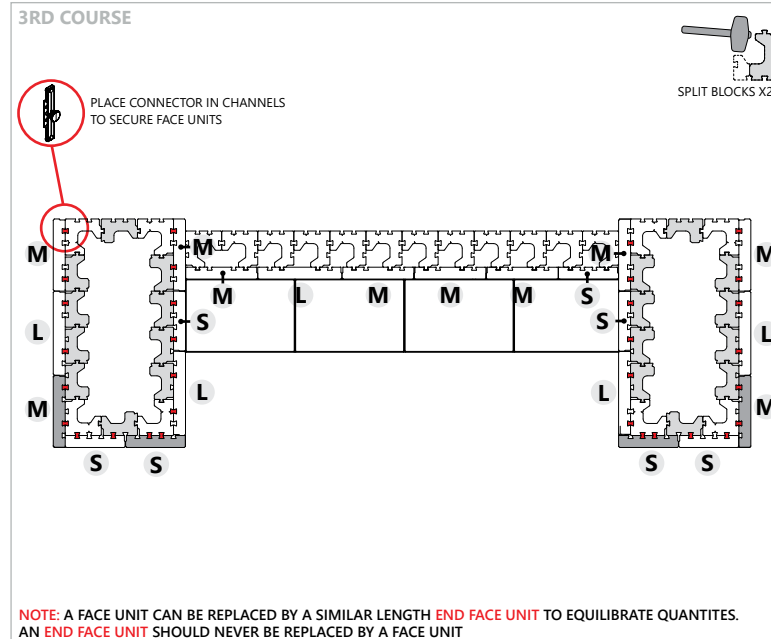
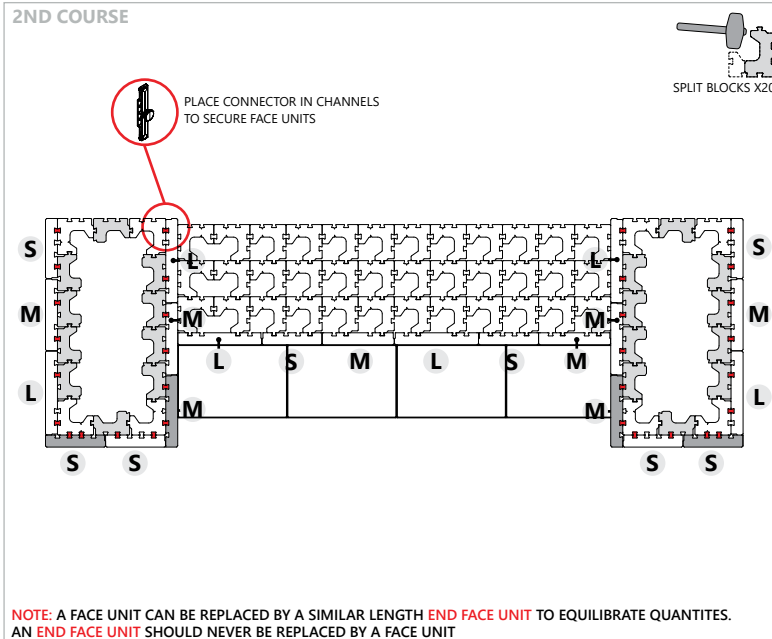

**COMPONENTS**  
NOTE: TANDEM UNITS ARE AVAILABLE IN MULTIPLE FACE STYLES

	<b>SMALL FACE UNIT</b> 7 x 13 1/16 x 2 3/8 in	<b>22x</b>
	<b>SMALL FACE END UNIT</b> 7 x 13 1/16 x 2 3/8 in	<b>8x</b>
	<b>MEDIUM FACE UNIT</b> 7 x 15 1/16 x 2 3/8 in	<b>24x</b>
	<b>MEDIUM FACE END UNIT</b> 7 x 15 1/16 x 2 3/8 in	<b>6x</b>
	<b>LARGE FACE END UNIT</b> 7 x 18 7/16 x 2 3/8 in	<b>23x</b>
<b>TOTAL QTY OF PALLETS</b>		<b>1x</b>
	<b>MODULAR BLOCK</b> 7 1/16 x 7 7/8 x 7 7/8 in	<b>228x</b>
<b>TOTAL QTY OF LAYERS</b>		<b>8x</b>
	<b>UNIVERSAL CONNECTOR</b> 5 3/4 x 1 1/4 x 1/8 in	<b>102x</b>
	<b>CAP</b> 24 x 16 x 2 3/8 in	<b>24x</b>
	<b>U-START UNIT</b> 18 7/16 x 16 x 3 3/8 in	<b>0x</b>
<b>TOTAL WEIGHT 10384 Lbs</b> Estimated weight concrete only, variations may occur due to product changes and cuts		

## 13 | Reinforced Steps

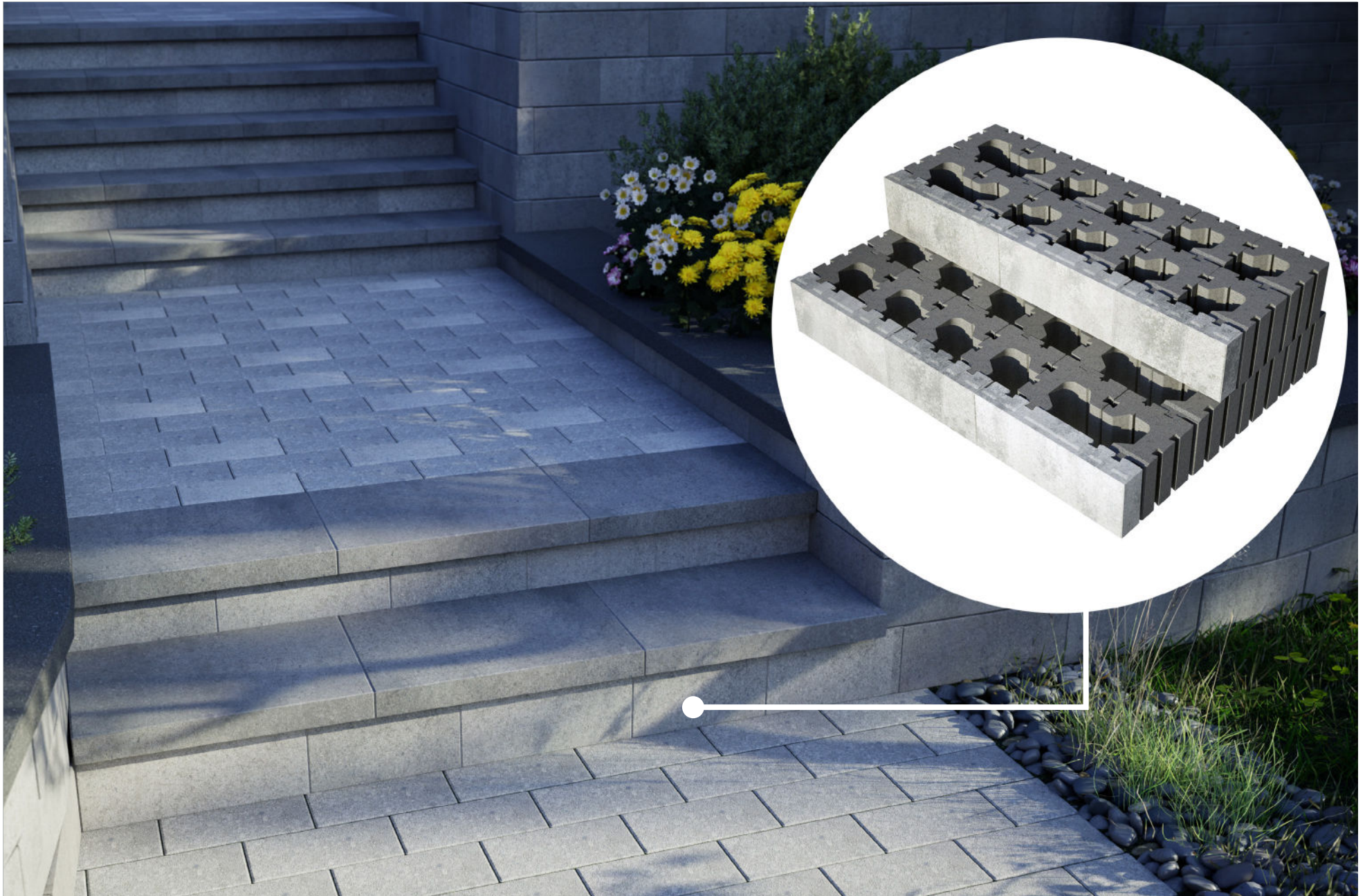

## 14 | Reinforced Corner Segmental Retaining Wall (SRW)



# 15 | Curved Segmental Retaining Wall (SRW)



## 16 | Gravity Wall With Multi-Stacked Blocks

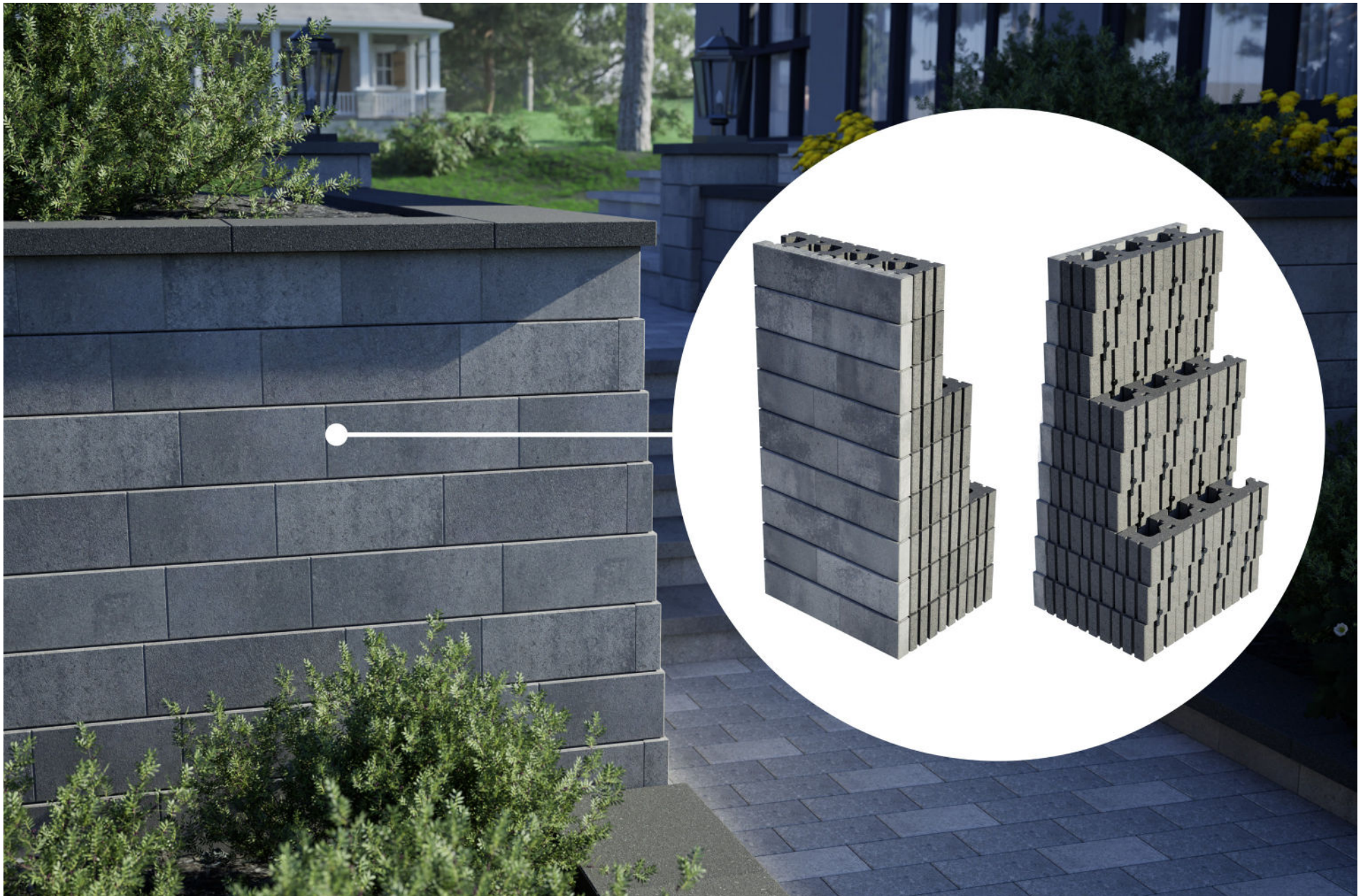



Oven

Smoker

Grill

Griddle

Refrigerator

Drawers

Cabinets

# NOW WE'RE COOKING CRAFTED FOR YOUR LIFESTYLE

Whether you just grill on the weekends or fancy yourself a full-time alfresco aficionado, your outdoor kitchen should reflect how you live. Define what matters most, so you can build a space that fits your lifestyle, not just your backyard.



SCAN HERE  
TO LEARN MORE  
ABOUT ELEMENTS

**BELGARD<sup>®</sup>**

AN OLDCASTLE<sup>®</sup> APG OUTDOOR BRAND

**BELGARD.COM**

© 2026 Oldcastle<sup>®</sup> APG, Inc. All Rights Reserved. BEL26-D-682273 | Revised 04/2026

